



MINNIE

LED EMERGENCY TWIN LIGHT



MR203L NC (3)

SAFETY INFORMATION

- **Please read and follow this product guide.**
- Servicing and installation of this product must only be done by qualified electrical personnel.
- Do not expose this product to dripping or splashing. Liquids may cause failure and/or fire hazard.
- Replace with Maxspid-approved battery only. Incorrectly replaced battery may cause failure and/or fire.
- Match the polarities of the mains supply with the terminal block and ensure it is firmly secured. Mismatch may cause electric shock.

INSTALLATION GUIDE

Unit Description

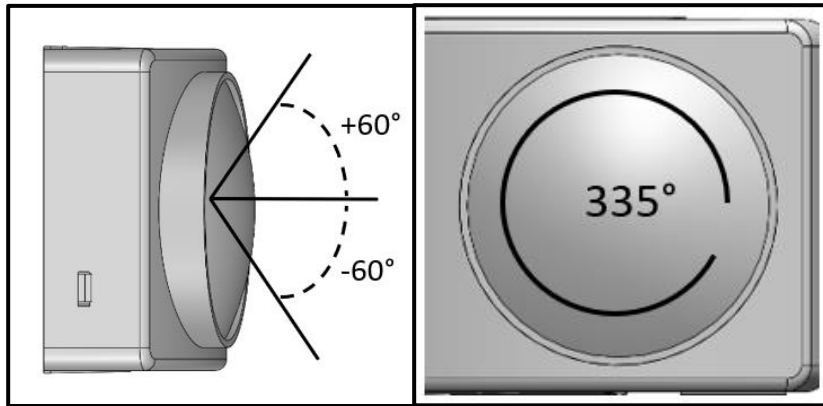

Angle of Rotation

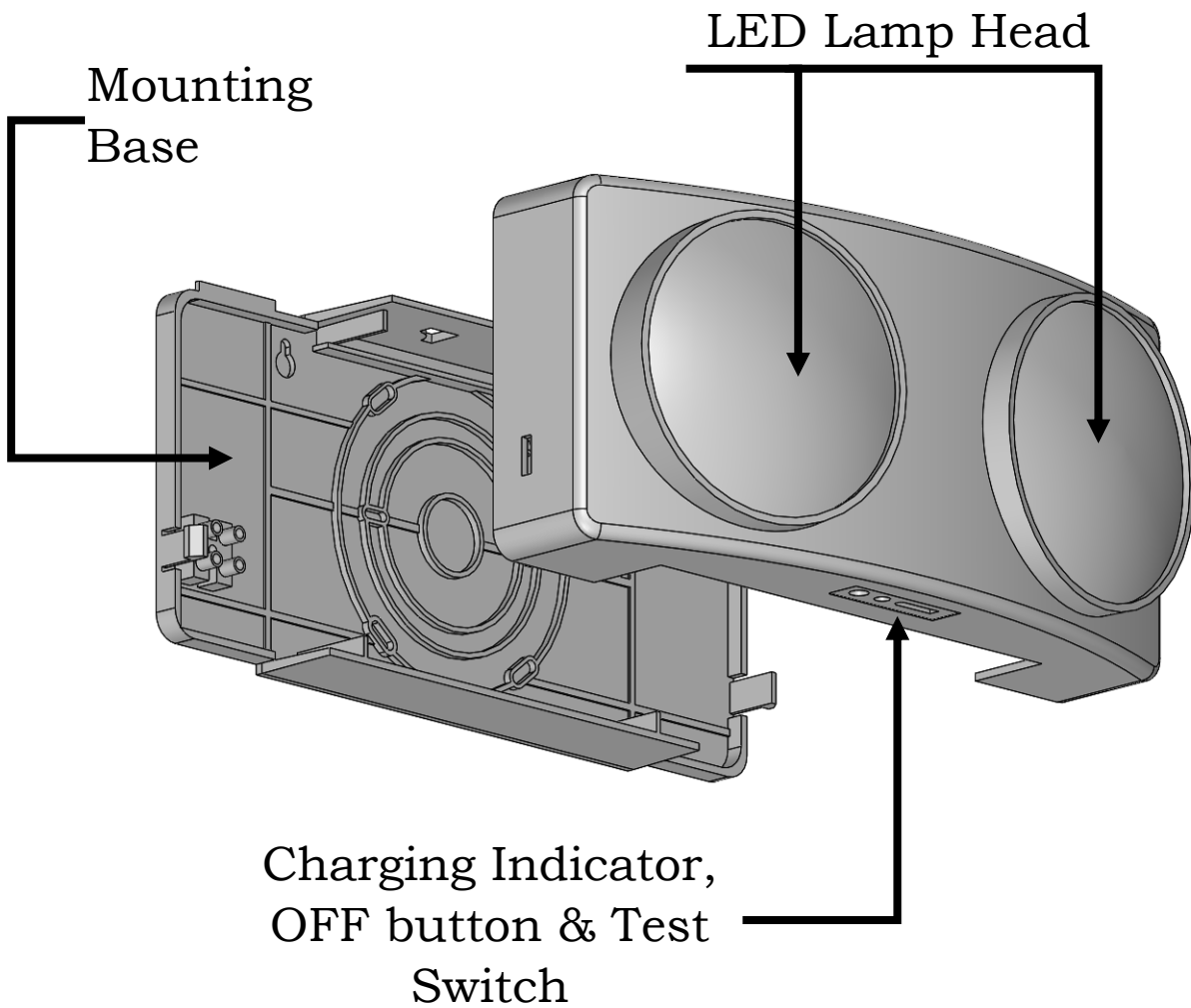

Mounting Guide

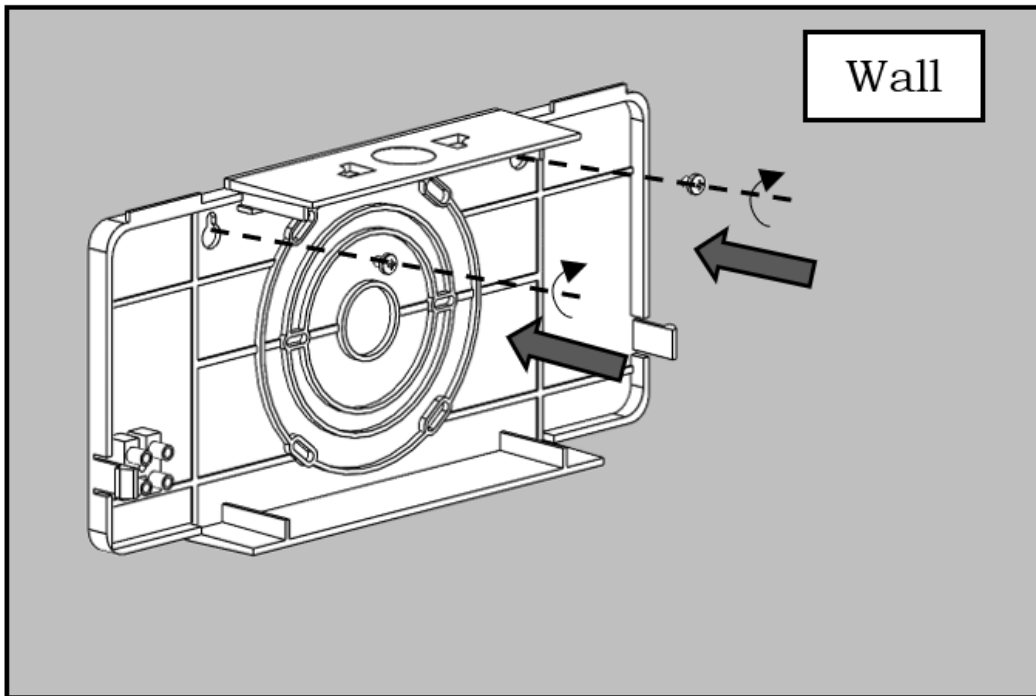

Mains Supply Connection

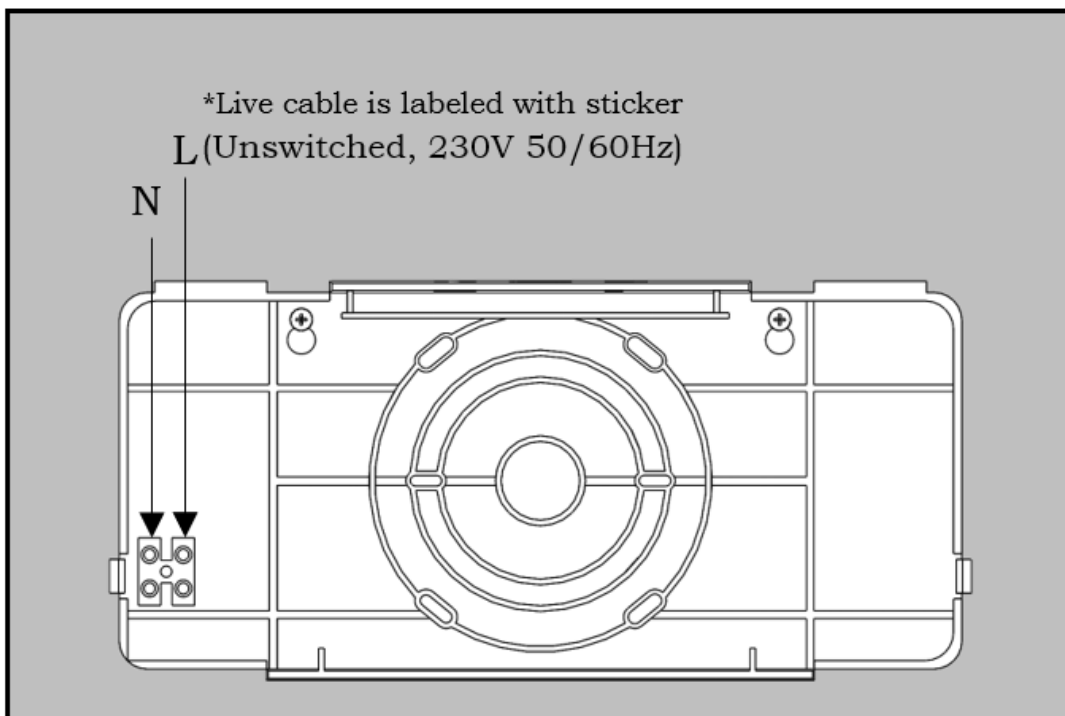

Note:

- LED charge indicator will be lit if installation is done properly.
- While AC power supply is connected, pressing test button will trigger emergency mode.
- If AC power supply is disconnected, the product will automatically changeover to emergency mode which can be switched off by pressing the OFF button. Pressing test button will resume emergency mode.
- For first usage, ensure mains supply to the unit is turned on for 24 hours to fully charge the battery.
**Interrupting the mains supply will discharge the battery.*
- For complete maintenance procedures for self-contained emergency escape luminaires and exit signs, refer to Singapore Standard 563 Clause 13.
- Installation accessories are not provided unless otherwise stated.

TROUBLESHOOTING GUIDE

Problem	Possible Cause and Solution
Charge indicator off	No incoming mains supply
Unable to light up in emergency mode	Battery connector is disconnected
	Battery is flat; Ensure the mains supply is turned on to allow the battery to fully charge
Duration of lighting up in emergency mode is too short	Battery is not properly charged; Ensure the mains supply is turned on to allow the battery to fully charge; Ensure there is no interruption of power supply for 24 hours