

EMERGENCY LIGHTS MINNIE

LED Economical non-maintained emergency twin light

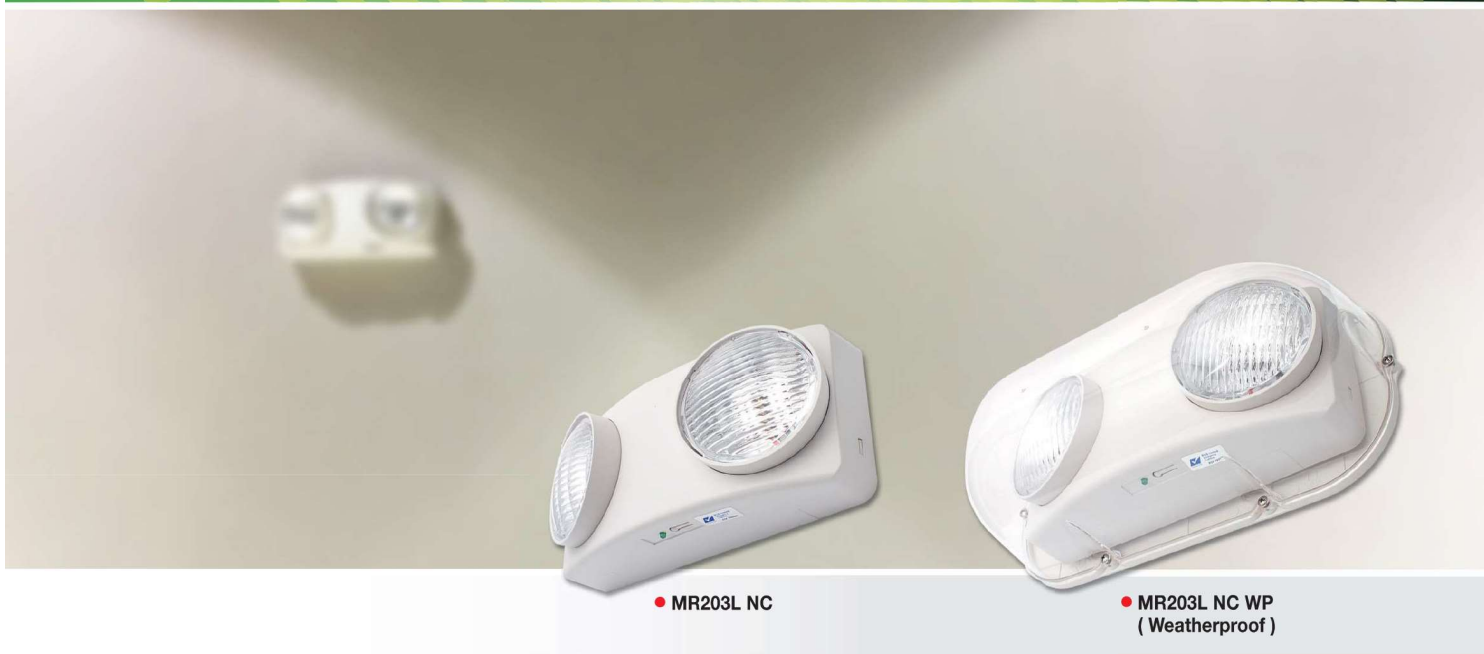

● MR203L NC

● MR203L NC WP
(Weatherproof)

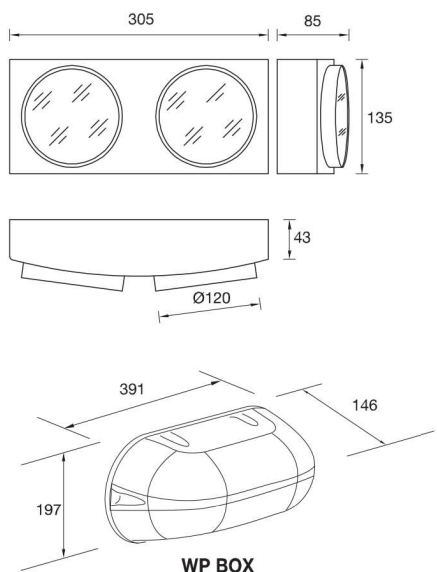

Dimension: mm NTS

High Power L.E.D

KEY FEATURES

- > High Brightness Output
- > High Lumen/watt Efficiency
- > Low Power Consumption
- > Low Maintenance
- > Long Lifespan

TECHNICAL DATA

- Mode of Operation : Non-Maintained
- Lamp : 2 x 3W High Power LED
- Rated Duration : 2 hrs and others
- Mains Supply : 230 Volts, 50/60Hz
- Power Consumption : < 1.1W
- Battery : High temp Nickel Cadmium
- Charge Monitor : Green LED Ø5mm
- Test Facility : Micro switch
- Safety Feature : Low volt cut-off preventing battery overdischarge
- Fitting Construction : Injection moulded thermoplastic ABS;
UL 94V-0 flame rating, two fully adjustable glare-free round shaped heads
- Mounting : Wall or ceiling. The snap-fit design will facilitate easy installations. Easily removable mounting and knockout holes are provided
- Cable Entry : Ø20mm K/O hole
- Weight : 1.2kg (gross)
- Compliance : SS 563 : Part 1 & 2, SS IEC 60598-2-22
- Warranty : 1 year

ORDERING GUIDE (Please check with Sales Dept if customisation is required)

Model	Lamp	Battery type
MR203L NC	2 x 3W LED	Nickel Cadmium
MR203L NC WP	2 x 3W LED	Nickel Cadmium



Type and batch tested with
PSB PLS-LISTED LABEL

Surface Mount
Energy Efficient
Emergency Luminaire



IP30 / IP54



Specifications subject to changes without prior notice.

