

EMERGENCY LIGHTS UFO

LED non-maintained emergency light

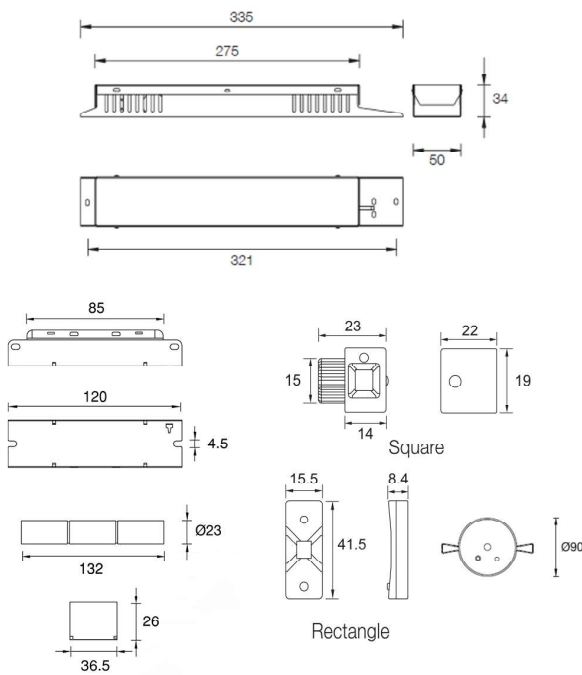

Dimension: mm NTS

High Power L.E.D

KEY FEATURES

- > High Brightness Output
- > High Lumen/watt Efficiency
- > Low Power Consumption
- > Low Maintenance
- > Long Lifespan

 Type and batch tested with
PSB PLS-LISTED LABEL



TECHNICAL DATA

Mode of Operation	: Non-maintained
Lamp	: 3W High Power LED
Rated Duration	: 3hrs and others
Mains Supply	: 230 Volts, 50/60Hz
Power Consumption	: < 0.9W
Battery	: High temp Nickel Cadmium
Charge Monitor	: Green LED
Test Facility	: Tactile switch / Push button switch
Safety Feature	: Low volt cut-off preventing battery overdischarge
Fitting Construction	: Electro galvanised steel with epoxy powder coating
Weight (Module only)	: 0.10 kg (gross)
Compliance	: SS 563 : Part 1 & 2, SS IEC 60598-2-22
Warranty	: 1 year

ORDERING GUIDE (Please check with Sales Dept if customisation is required)

Model	Lamp	Battery type
UFR.3.NC180.NM (AUX)	3W LED	Nickel Cadmium