

EMERGENCY POWER PACKS CONVERSION KIT

Emergency kit for LED lamp fitting



● MEM/M/LED-ATS

● 3.6V 1.7AH
Ni-Cd

or

● 3.2V 3.3AH
Lithium

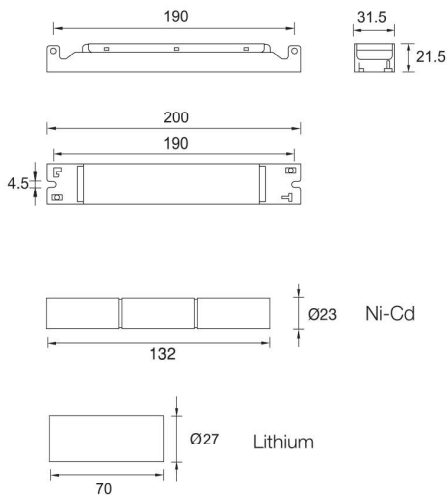

Dimension: mm NTS



LED Lamp



Type and batch tested with
PSB PLS-LISTED LABEL



TECHNICAL DATA

Mode of Operation	: Maintained*
Lamp	: LED Module
Rated Duration	: 3hrs and others
Mains Supply	: 230 Volts, 50/60Hz
Power Consumption	: < 2.9W
Battery	: High temp Nickel Cadmium / Lithium
Charge Monitor	: Green LED Ø5mm
Test Facility	: Push button switch
Safety Feature	: Low volt cut-off preventing battery overdischarge
Fitting Construction	: Electro galvanised steel with epoxy powder coating
Weight (Module only)	: 0.14kg (gross)
Compliance	: IEC 61347-2-7, IEC 61347-2-13, IEC 62384
Warranty	: 1 year

ORDERING GUIDE (Please check with Sales Dept if customisation is required)

Model	Lamp
MEM/M/LED-ATS	LED Module

*Note:

Can be incorporated into combined maintained, combined non-maintained and non-maintained mode of operation.

** Please ensure that your LED Lamp & Driver are suitable for Emergency installation.