



Always leading the way with you

www.maxspid.com

EMERGENCY EXIT LIGHTS

SLIMLINE

SLS.M.SE.NC180.WLF	1
SLR.M.SE.NC180.WLF	2

LEDER

ES/M/W5100	3
ESR/M/W5100	4

CLASSIC

JWS/M/W5100	5
-------------	---

FINESCO

KL/M/W5100	6
------------	---

BOXSTER

BLS/M/W5100	7
BHD/M/W5100 (R/L)	8

BOXSTER RECESS

BLR/M/W510RM (E) MINI	9
BLR/M/W5100 (R)	10

EMERGENCY POWER PACKS

CONVERSION KIT

MEM/M/128E MINI	11
MEM/M/LED MINI	12

POWER PACK

MPP/M/PLC13-18E NC	13
MPP/M/LED	14

BRITE LITE

EXN/M/150	15
-----------	----

STARLITE

UFO/NM/L101 NC (AUXILIARY)	16
UFO/NM/L103 (AUXILIARY)	17

EMERGENCY LIGHTS

UFO

UFR.3.NC180.NM	18
UBDR.10.NC120.NM	19

UFO

UF.3.NC180.NM	20
UF.10.NC120.NM	21

MINNIE

MR203L NC	22
-----------	----

PROVIDER

PP203L NC	23
-----------	----

CLASSIC

JW/NM/W5100	24
-------------	----

TWIN LAMP

MTL/NM/L203 NC	25
----------------	----

CONTENTS



NON PSB PLS-LISTED PRODUCTS

LEDER

ES/W5100 (SLAVE)	26
------------------	----

BOXER

MLS/W5100 (SLAVE)	27
-------------------	----

CONVERSION KIT

PL/M/PL7-PLC13 NC	28
MEM/M/LED-AC MINI	29

POWER PACK

MPP/M/PL7-PLC26	30
-----------------	----

TRILITE

TL/210RM	31
----------	----

TECHNICAL INFORMATION

STANDARD MODES OF OPERATION	32
--------------------------------	----

OPERATION AND WIRING INFORMATION	33-37
-------------------------------------	-------

LIST OF SYMBOL/MARKING

SYMBOL AND MARKING INFORMATION	38
-----------------------------------	----

www.maxspid.com



MISSION STATEMENT

To be the region's leading choice for emergency lighting solutions through constant innovation, quality products and excellent services.

KEY MILESTONES

1978

Founded as a sole proprietorship

1982

Turned into an incorporation

1994

Awarded the ISO 9000 certification award by PSB

1999

Expanded into a 5-storey terrace factory

2008

Regional expansion

2009

Recognised market leader in Singapore's emergency lighting industry





QUALITY PRODUCTS

Maxspid products are built to adhere strictly to the Singapore Standard 563, 508 and IEC 60598-2-22. Also, our products are type and batch tested with PSB PLS-listed label.

The product range includes emergency exit lights, emergency power packs and emergency lights.

All our products are guaranteed to be of the highest quality possible. This is only achievable through strict adherence to total quality management and use of quality and reputable component brands. Strict control test awaits each item at the end of the production line when the finished product is put on a test rack for an on-load multiple cycle life tests.



CONSTANT INNOVATION

Maxspid always interacts with its clients and channel for new product ideas. Only in this way can the company stay ahead through technology advancement and a keen sense for customer needs.

As such, we have developed more than 50 different models of emergency lighting products. Our products are used in all types of buildings, including residential, industrial and commercial purposes. Our manufacturing process includes assembly testing, APGB and SMT production.



EXCELLENT SERVICES

All customers have their unique requirements. Therefore, Maxspid offers customisation of designs, technical assistance and after-sales assistance. Our customers can expect prompt follow-ups and servicing within the stipulated warranty period.

To realise on prompt delivery of orders and short lead times, Maxspid keeps a substantial stock of raw materials. The maximum time for electrical components is in weeks, a couple of months at most.

Our overseas clients can access Maxspid products and services through distributors and agents. We are entering more overseas market such as Vietnam, Indonesia, India, Sri Lanka, Brunei Darussalam, Myanmar, Malaysia, UAE, Australia and Philippines.



PROJECTS

AIRPORT

Changi Airport Cargo Building (CAAS)
Changi Airport Terminal 1
Changi Airport Terminal 2
Changi Airport Terminal 3
Jewel @ Changi Airport

COMPANY BUILDING

Applied Material S,E,A Pte Ltd
Asia Square Tower 1
Asia Square Tower 2
Biopolis
Capitagreen @ Market Street
Capital Tower
Cleantech
Cleantech Park 2
Credit Suisse
Energizer
Equinix
Global Switch @ Woodlands
Google Centre @ Penjuru
JTC Furniture Mall @ Sungei Kadut
JTC Space @ Tuas
M1 Building @ International Business Park
MBFC Tower 1, 2, 3
Mediacorp
Micron @ Admiralty
Microsoft @ Woodlands
NTUC Fairprice Hub @ Joo Koon
One Marina
OUB Centre
OUBC @ 1 Raffles Place
OUE Downtown
Oxley Bizhub 1
Oxley Bizhub 2
P & G Innovation Center
Panasonic Semiconductor
Paya Lebar Square
Prime Biz Hub
Robert Bosch @ Bishan
Robinson Tower
Royal Square @ Novena
Seagate 1, 2, 3 @ Woodlands
Selegie Complex
Shine @ Tuas South
Singapore Power HQ
Solaris @ Kallang 164
South Beach Development
Starhub @ Mediapolis
Tanjong Kling Factory
Treasury Building
Victoria Theatre & Concert Hall
Woods Square

CONDOMINIUM

Ascentia Sky Condo
Bijou Condo
Blue Horizon Condo
City Light Condo
D' Leedon Condo
Forest Woods Condo
Interlace Condo
Marina Bay Suite
NV Residence
Pinnacle @ Sentosa
Skyline @ Orchard Boulevard
South Beach Residence
Waterplace Condo
Westwood Residence

EDUCATION INSTITUTION

Australian International School
French School
Nafa Campus
Ngee Ann Polytechnic
NTU
NUS
Overseas Family School
Raffles Institution
School of the Arts
SIM
Singapore Chinese Girls' School
Singapore Polytechnic
Singapore Institute of Technology (SIT)
SMU
Stamford American International School
SUTD
Temasek Polytechnic

GOVERNMENT

BCA Academy
Changi Airbase
Changi Naval Base
Changi Prison Cluster B
Fusionpolis
Gurkha Camp
Hendon Camp
ICA Building
Jurong Camp
Kranji Camp
LTA - Gali Batu Depot
LTA - Kranji Depot
LTA - Tuas Depot
Mandai Camp
MRT - Circle Line 1, 3, 4 & 5
MRT - Downtown Line
MRT - Thomson East Coast Line
National Archives of Singapore
National Art Gallery
Nee Soon Camp
Parliament House
Police Cantonment Complex
PUB Waterhub
Selarang Camp
Sembawang Camp
Supreme Court
Tuas Checkpoint
Tuas Naval Base
Various HDB Upgrading (LUP, MUP)
Various MRT Station
Woodlands Checkpoint

HEALTHCARE

Alexandra Hospital
Changi General Hospital
Changi Medical Centre
Farrer Park Hospital
Institute of Mental Health
KK Hospital
National Cancer Centre
National Heart Centre
New Rencis Hospital
NUH
Outram Community Hospital
Pioneer Polyclinic
SGH
Sengkang Hospital
Tan Tock Seng Hospital
Thye Hwa Kuan

HOTEL

Amara Hotel
Carlton Hotel
Dorsett Hotel
Fairmont Hotel
Grand Park City Hall Hotel
Grand Park Orchard Hotel
Holiday Inn Parkview Hotel
Hotel Le Meridian Singapore
Hotel Phoenix
Intercontinental Hotel
Mandarin Orchard Singapore
Oasia Downtown Hotel
One Fullerton
Orchard Hotel
Parkroyal Hotel @ Pickering
Raffles Hotel
Genting Hotel Jurong
Sentosa Hotel
Shangri-La Hotel
Swissotel
St. Regis Hotel
The Outpost Hotel @ Sentosa
The Pines Club Hotel
Tyrwhitt Hotel
Village Hotel @ Sentosa
W Hotel @ Quayside
Zhong Shan Park Hotel

INTEGRATED RESORTS (IR)

Marina Bay Sands
Resort World @ Sentosa

SHOPPING MALL

111 Somerset
AMK Hub
Bedok Hub
Bugis Junction
Causeway Point
Century Square
Chinatown Point
City Square Mall
Great World City
IMM
ION Orchard
Katong Shopping Mall
Marina Square
Northpoint
Orchard Emerald
Paya Lebar Quarter
Raffles Link
Scotts Square
Seletar Mall
Singapore Flyer
Star Vista
Sun Plaza
Suntec City A & A
The Cathay Gallery

EMERGENCY EXIT LIGHTS SLIMLINE

SMT LED with lifespan 50,000 burning hours
SMT LED surface mount emergency exit light



● **SLS.M.SRE.NC180.WLF**

Running-man graphical exit signs
comply to latest SS 563 & SS 508

● **SLS.M.SE.NC180.WLF**

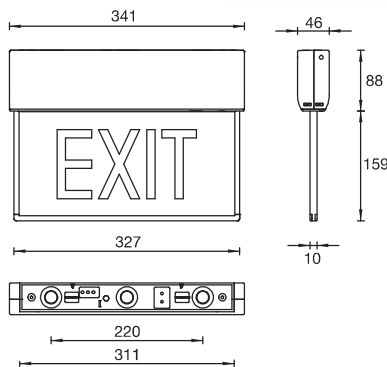

Dimension: mm NTS

TECHNICAL DATA

Mode of Operation	: Maintained
Lamp	: 1.5W SMT LED
Rated Duration	: 3 hrs and others
Mains Supply	: 230 Volts, 50/60Hz
Power Consumption	: < 3W
Battery	: High temp Nickel Cadmium/Lithium
Charge Monitor	: Green LED (normal) / Red LED (error)
Test Facility	: Tactile switch
Safety Feature	: Low volt cut-off preventing battery overdischarge
Fitting Construction	: Injection moulded fire retardant acrylonitrile butadiene styrene (ABS)
Diffuser	: Fire retardant moulded acrylic
Mounting	: Wall or ceiling
Cable Entry	: Ø20mm K/O hole
Weight	: 1.0kg (gross)
Compliance	: SS 563 : Part 1 & 2, SS IEC 60598-2-22
Warranty	: 1 year

KEY FEATURES

- > Using Surface Mount Technology LED
- > High Durability & Reliability
- > Low Heat
- > Low Maintenance
- > Low Power Consumption
- > No "Black Ends"
- > Self Testing Function
- > Malfunction Indicator
- > Versatile & User Customisable



Type and batch tested with
PSB PLS-LISTED LABEL

Surface Mount
Internal Lit
LED Slim Exit Sign



ORDERING GUIDE (Please check with Sales Dept if customisation is required)

Single Sided	Double Sided	Legend
SLS.M.SE.NC180.WLF	SLS.M.DE.NC180.WLF	
SLS.M.SEE.NC180.WLF	SLS.M.DEE.NC180.WLF	
SLS.M.SEW.NC180.WLF	SLS.M.DEE.NC180.WLF	
SLS.M.SR.NC180.WLF	SLS.M.DR.NC180.WLF	
SLS.M.SRE.NC180.WLF	SLS.M.DRE.NC180.WLF	
SLS.M.SRW.NC180.WLF	SLS.M.DRE.NC180.WLF	
SLS.M.SRS.NC180.WLF		
SLS.M.SRN.NC180.WLF		

SMT LED with lifespan 50,000 burning hours
SMT LED recess mount emergency exit light

EMERGENCY EXIT LIGHTS SLIMLINE



● **SLR.M.SRE.NC180.WLF**
Running-man graphical exit signs
comply to latest SS 563 & SS 508

● **SLR.M.SE.NC180.WLF**

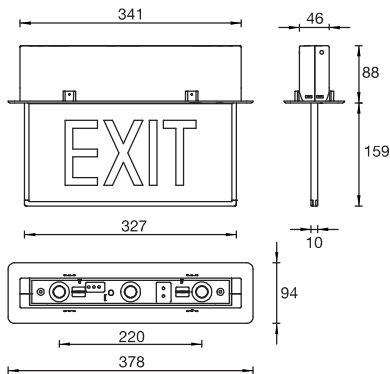

Dimension: mm NTS

TECHNICAL DATA

- Mode of Operation : Maintained
- Lamp : 1.5W SMT LED
- Rated Duration : 3 hrs and others
- Mains Supply : 230 Volts, 50/60Hz
- Power Consumption : < 3W
- Battery : High temp Nickel Cadmium/Lithium
- Charge Monitor : Green LED (normal) / Red LED (error)
- Test Facility : Tactile switch
- Safety Feature : Low volt cut-off preventing battery overdischarge
- Fitting Construction : Injection moulded fire retardant acrylonitrile butadiene styrene (ABS)
- Diffuser : Fire retardant moulded acrylic
- Mounting : Wall or ceiling
- Cable Entry : Ø20mm K/O hole
- Weight : 1.0kg (gross)
- Compliance : SS 563 : Part 1 & 2, SS IEC 60598-2-22
- Warranty : 1 year

KEY FEATURES

- > Using Surface Mount Technology LED
- > High Durability & Reliability
- > Low Heat
- > Low Maintenance
- > Low Power Consumption
- > No "Black Ends"
- > Self Testing Function
- > Malfunction Indicator
- > Versatile & User Customisable



Type and batch tested with
PSB PLS-LISTED LABEL



350 x 80mm

Recess Mount
Internal Lit
LED Slim Exit Sign

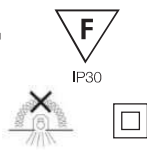

ORDERING GUIDE (Please check with Sales Dept if customisation is required)

Single Sided	Double Sided	Legend
SLR.M.SE.NC180.WLF	SLR.M.DE.NC180.WLF	
SLR.M.SEE.NC180.WLF	SLR.M.DEE.NC180.WLF	
SLR.M.SEW.NC180.WLF	SLR.M.DEE.NC180.WLF	
SLR.M.SR.NC180.WLF	SLR.M.DR.NC180.WLF	
SLR.M.SRE.NC180.WLF	SLR.M.DRE.NC180.WLF	
SLR.M.SRW.NC180.WLF	SLR.M.DRE.NC180.WLF	
SLR.M.SRS.NC180.WLF		
SLR.M.SRN.NC180.WLF		

EMERGENCY EXIT LIGHTS LEDER

SMT LED with lifespan 50,000 burning hours
SMT LED surface mount emergency exit light



● **ES/M/W510RM (E)**
Running-man graphical exit signs
comply to latest SS 563 & SS 508

● **ES/M/W5100**

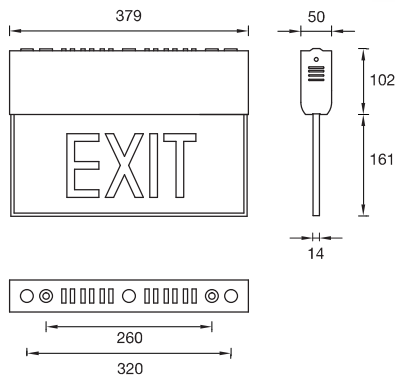

Dimension: mm NTS

TECHNICAL DATA

Mode of Operation	: Maintained
Lamp	: Maxspid 1W SMT LED Lamp
Rated Duration	: 2 hrs and others
Mains Supply	: 230 Volts, 50/60Hz
Power Consumption	: < 3W
Battery	: High temp Nickel Cadmium
Charge Monitor	: Green LED Ø5mm
Test Facility	: Micro switch
Safety Feature	: Low volt cut-off preventing battery overdischarge
Fitting Construction	: Electro galvanised steel with epoxy powder coating
Diffuser	: Fire retardant moulded acrylic
Mounting	: Wall or ceiling
Cable Entry	: Ø20mm K/O hole
Weight	: 2.5kg (gross)
Compliance	: SS 563 : Part 1 & 2, SS IEC 60598-2-22
Warranty	: 1 year

KEY FEATURES

- > Using Surface Mount Technology LED
- > High Durability & Reliability
- > Low Heat
- > Low Maintenance
- > Low Power Consumption
- > No "Black Ends"



Type and batch tested with
PSB PLS-LISTED LABEL

Surface Mount
Internal Lit
LED Slim Exit Sign



ORDERING GUIDE

(Please check with Sales Dept if customisation is required)

Single Sided	Double Sided	Legend
ES/M/W5100	ED/M/W5100	
ES/M/W5100 (R)	ED/M/W5100 (R/L)	
ES/M/W5100 (L)	ED/M/W5100 (R/L)	
ES/M/W5100 (D)	ED/M/W5100 (D)	
ES/M/W510RM	ED/M/W510RM	
ES/M/W510RM (E)	ED/M/W510RM (E/W)	
ES/M/W510RM (W)	ED/M/W510RM (E/W)	
ES/M/W510RM (S)	ED/M/W510RM (S)	
ES/M/W510RM (N)	ED/M/W510RM (N)	

SMT LED with lifespan 50,000 burning hours
SMT LED recess mount emergency exit light

EMERGENCY EXIT LIGHTS LEDER



● **ESR/M/W510RM (E)**
Running-man graphical exit signs
comply to latest SS 563 & SS 508

● **ESR/M/W5100**

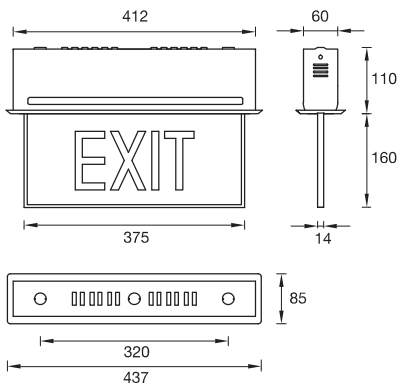

Dimension: mm NTS

TECHNICAL DATA

Mode of Operation	: Maintained
Lamp	: Maxspid 1W SMT LED Lamp
Rated Duration	: 2 hrs and others
Mains Supply	: 230 Volts, 50/60Hz
Power Consumption	: < 3W
Battery	: High temp Nickel Cadmium
Charge Monitor	: Green LED Ø5mm
Test Facility	: Micro switch
Safety Feature	: Low volt cut-off preventing battery overdischarge
Fitting Construction	: Electro galvanised steel with epoxy powder coating
Diffuser	: Fire retardant moulded acrylic
Mounting	: Wall or ceiling
Cable Entry	: Ø20mm K/O hole
Weight	: 2.5kg (gross)
Compliance	: SS 563 : Part 1 & 2, SS IEC 60598-2-22
Warranty	: 1 year

KEY FEATURES

- > Using Surface Mount Technology LED
- > High Durability & Reliability
- > Low Heat
- > Low Maintenance
- > Low Power Consumption
- > No "Black Ends"



Type and batch tested with
PSB PLS-LISTED LABEL



Recess Mount
Internal Lit
LED Slim Exit Sign
415 x 62mm



IP30
CLASS I

ORDERING GUIDE (Please check with Sales Dept if customisation is required)

Single Sided	Double Sided	Legend
ESR/M/W5100	EDR/M/W5100	
ESR/M/W5100 (R)	EDR/M/W5100 (R/L)	
ESR/M/W5100 (L)	EDR/M/W5100 (R/L)	
ESR/M/W5100 (D)	EDR/M/W5100 (D)	
ESR/M/W510RM	EDR/M/W510RM	
ESR/M/W510RM (E)	EDR/M/W510RM (E/W)	
ESR/M/W510RM (W)	EDR/M/W510RM (E/W)	
ESR/M/W510RM (S)	EDR/M/W510RM (S)	
ESR/M/W510RM (N)	EDR/M/W510RM (N)	

EMERGENCY EXIT LIGHTS CLASSIC

SMT LED with lifespan 50,000 burning hours
Indoor, outdoor, corrosion resistant weatherproof emergency exit light



● **JWS/M/W510RM (E)**
Running-man graphical exit signs
comply to latest SS 563 & SS 508

● **JWS/M/W5100**

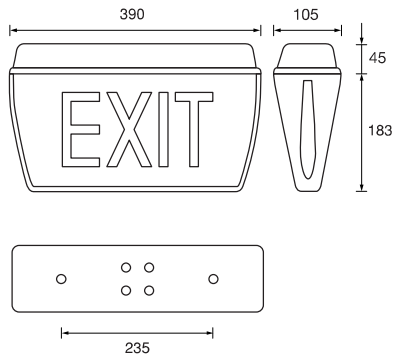

Dimension: mm NTS

TECHNICAL DATA

Mode of Operation	: Maintained
Lamp	: Maxspid 1W SMT LED Lamp
Rated Duration	: 2 hrs and others
Mains Supply	: 230 Volts, 50/60Hz
Power Consumption	: < 3W
Battery	: High temp Nickel Cadmium
Charge Monitor	: Green LED Ø5mm
Test Facility	: Push button switch
Safety Feature	: Low volt cut-off preventing battery overdischarge
Housing & Diffuser	: Injection moulded fire retardant, high impact polycarbonate
Mounting	: Wall or ceiling
Cable Entry	: Ø20mm K/O hole
Weight	: 1.5kg (gross)
Compliance	: SS 563 : Part 1 & 2, SS IEC 60598-2-22
Warranty	: 1 year

KEY FEATURES

- > Using Surface Mount Technology LED
- > High Durability & Reliability
- > Low Heat
- > Low Maintenance
- > Low Power Consumption
- > No "Black Ends"



Type and batch tested with
PSB PLS-LISTED LABEL

Surface Mount
Weatherproof
Exit Sign



ORDERING GUIDE (Please check with Sales Dept if customisation is required)

Single Sided	Double Sided	Legend
JWS/M/W5100	JWD/M/W5100	
JWS/M/W5100 (R)	JWD/M/W5100 (R/L)	
JWS/M/W5100 (L)	JWD/M/W5100 (R/L)	
JWS/M/W510RM	JWD/M/W510RM	
JWS/M/W510RM (E)	JWD/M/W510RM (E/W)	
JWS/M/W510RM (W)	JWD/M/W510RM (E/W)	

*Heating strip applicable (for cold room used)



Specifications subject to changes without prior notice.



SMT LED with lifespan 50,000 burning hours
Indoor, outdoor, corrosion resistant weatherproof emergency exit light

EMERGENCY EXIT LIGHTS FINESCO



● **KL/M/W510RM (E)**
Running-man graphical exit signs
comply to latest SS 563 & SS 508

● **KL/M/W5100**

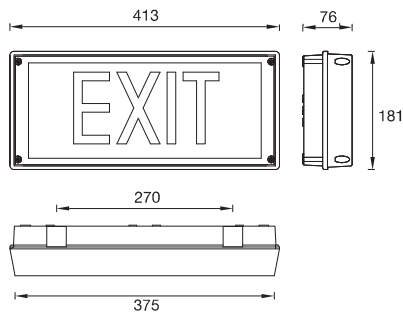

Dimension: mm NTS

TECHNICAL DATA

Mode of Operation	: Maintained
Lamp	: Maxspid 1W SMT LED Lamp
Rated Duration	: 2 hrs and others
Mains Supply	: 230 Volts, 50/60Hz
Power Consumption	: < 3W
Battery	: High temp Nickel Cadmium
Charge Monitor	: Green LED Ø5mm
Test Facility	: Push button switch
Safety Feature	: Low volt cut-off preventing battery overdischarge
Housing & Diffuser	: Injection moulded fire retardant, high impact polycarbonate
Mounting	: Wall, ceiling suspended or semi-recessed
Cable Entry	: Ø20mm K/O hole
Weight	: 1.6kg (gross)
Compliance	: SS 563 : Part 1 & 2, SS IEC 60598-2-22
Warranty	: 1 year

KEY FEATURES

- > Using Surface Mount Technology LED
- > High Durability & Reliability
- > Low Heat
- > Low Maintenance
- > Low Power Consumption
- > No "Black Ends"



Surface/Semi-recessed
Mount Weatherproof
Exit Sign



ORDERING GUIDE (Please check with Sales Dept if customisation is required)

Single Sided	Legend
KL/M/W5100	
KL/M/W5100 (R)	
KL/M/W5100 (L)	
KL/M/W510RM	
KL/M/W510RM (E)	
KL/M/W510RM (W)	

*Heating strip applicable (for cold room used)

EMERGENCY EXIT LIGHTS BOXSTER

SMT LED with lifespan 50,000 burning hours
Box type single sided emergency exit light



● **BLS/M/W510RM (E)**

Running-man graphical exit signs
comply to latest SS 563 & SS 508

● **BLS/M/W5100**

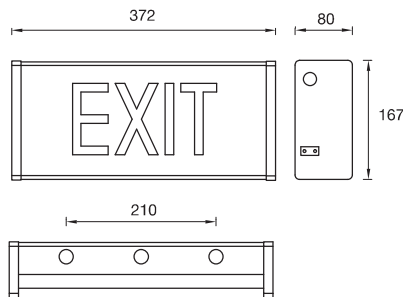

Dimension: mm NTS

TECHNICAL DATA

Mode of Operation	: Maintained
Lamp	: Maxspid 1W SMT LED Lamp
Rated Duration	: 2 hrs and others
Mains Supply	: 230 Volts, 50/60Hz
Power Consumption	: < 3W
Battery	: High temp Nickel Cadmium
Charge Monitor	: Green LED Ø5mm
Test Facility	: Micro switch
Safety Feature	: Low volt cut-off preventing battery overdischarge
Fitting Construction	: Electro galvanised steel with epoxy powder coating
Diffuser	: Fire retardant moulded acrylic
Mounting	: Wall or ceiling
Cable Entry	: Ø20mm K/O hole
Weight	: 2.0kg (gross)
Compliance	: SS 563 : Part 1 & 2, SS IEC 60598-2-22
Warranty	: 1 year

KEY FEATURES

- > Using Surface Mount Technology LED
- > High Durability & Reliability
- > Low Heat
- > Low Maintenance
- > Low Power Consumption
- > No "Black Ends"

ORDERING GUIDE (Please check with Sales Dept if customisation is required)

Single Sided	Legend
BLS/M/W5100	
BLS/M/W5100 (R)	
BLS/M/W5100 (L)	
BLS/M/W510RM	
BLS/M/W510RM (E)	
BLS/M/W510RM (W)	

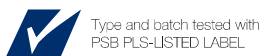

Surface Mount
Box Exit Sign



Specifications subject to changes without prior notice.



LED with lifespan 50,000 burning hours
Box type double sided emergency exit light

EMERGENCY EXIT LIGHTS DOUBLE SIDED BOXSTER



● **BHD/M/W510RM (E/W)**
Running-man graphical exit signs
comply to latest SS 563 & SS 508

● **BHD/M/W5100 (R/L)**

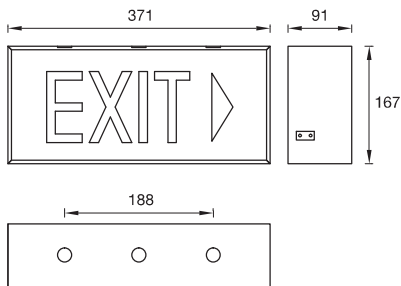

Dimension: mm NTS

TECHNICAL DATA

Mode of Operation	: Maintained
Lamp	: Maxspid 1W SMT LED Lamp (x2)
Rated Duration	: 2 hrs and others
Mains Supply	: 230 Volts, 50/60Hz
Power Consumption	: <3W
Battery	: High temp Nickel Cadmium
Charge Monitor	: Green LED Ø5mm
Test Facility	: Micro switch
Safety Feature	: Low volt cut-off preventing battery overdischarge
Fitting Construction	: Electro galvanised steel with epoxy powder coating
Diffuser	: Fire retardant moulded acrylic
Mounting	: Ceiling
Cable Entry	: Ø20mm K/O hole
Weight	: 1.7kg (gross)
Compliance	: SS 563 : Part 1 & 2, SS IEC 60598-2-22
Warranty	: 1 year

KEY FEATURES

- > Using Surface Mount Technology LED
- > High Durability & Reliability
- > Low Heat
- > Low Maintenance
- > Low Power Consumption
- > No "Black Ends"

ORDERING GUIDE (Please check with Sales Dept. if customisation is required)

Double Sided	Legend
BHD/M/W5100	
BHD/M/W5100 (R/L)	
BHD/M/W5100 (R/L)	
BHD/M/W510RM	
BHD/M/W510RM (E/W)	
BHD/M/W510RM (E/W)	



Surface Mount
Box Exit Sign



EMERGENCY EXIT LIGHTS BOXSTER RECESS

SMT LED with lifespan 50,000 burning hours
Fully-recessed low level SMT LED emergency
exit light



● **BLR/M/W510RM (E) MINI**
Running-man graphical exit signs
comply to latest SS 563 & SS 508

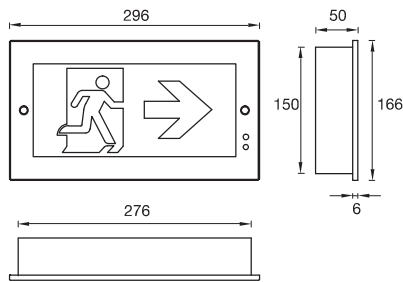

Dimension: mm NTS

TECHNICAL DATA

Mode of Operation	: Maintained
Lamp	: Maxspid 1W SMT LED Lamp
Rated Duration	: 2 hrs and others
Mains Supply	: 230 Volts, 50/60Hz
Power Consumption	: < 3W
Battery	: High temp Nickel Cadmium
Charge Monitor	: Green LED Ø5mm
Test Facility	: Micro switch
Safety Feature	: Low volt cut-off preventing battery overdischarge
Fitting Construction	: Electro galvanised steel with epoxy powder coating
Diffuser	: Fire retardant moulded acrylic
Mounting	: Wall fully-recessed
Cable Entry	: Ø20mm K/O hole
Weight	: 1.6kg (gross)
Compliance	: SS 563 : Part 1 & 2, SS IEC 60598-2-22
Warranty	: 1 year

KEY FEATURES

- > Using Surface Mount Technology LED
- > High Durability & Reliability
- > Low Heat
- > Low Maintenance
- > Low Power Consumption
- > No "Black Ends"

ORDERING GUIDE (Please check with Sales Dept if customisation is required)

Single Sided	Legend
BLR/M/W510RM MINI	
BLR/M/W510RM (E) MINI	
BLR/M/W510RM (W) MINI	



Type and batch tested with
PSB PLS-LISTED LABEL



280 x 153mm

Fully-recessed
Low Level Exit Sign



IP30
CLASS I



Specifications subject to changes without prior notice.



SMT LED with lifespan 50,000 burning hours
Fully-recessed low level SMT LED
emergency exit light

EMERGENCY EXIT LIGHTS BOXSTER RECESS



● **BLR/M/W510RM (E)**
Running-man graphical exit signs
comply to latest SS 563 & SS 508

● **BLR/M/W5100 (R)**

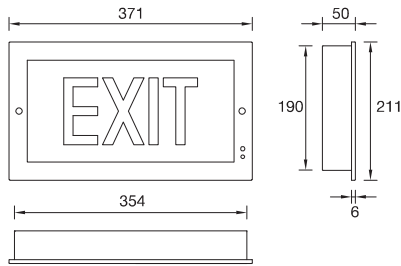

Dimension: mm NTS

TECHNICAL DATA

Mode of Operation	: Maintained
Lamp	: Maxspid 1W SMT LED Lamp
Rated Duration	: 2 hrs and others
Mains Supply	: 230 Volts, 50/60Hz
Power Consumption	: < 3W
Battery	: High temp Nickel Cadmium
Charge Monitor	: Green LED Ø5mm
Test Facility	: Micro switch
Safety Feature	: Low volt cut-off preventing battery overdischarge
Fitting Construction	: Electro galvanised steel with epoxy powder coating
Diffuser	: Fire retardant moulded acrylic
Mounting	: Wall fully-recessed
Cable Entry	: Ø20mm K/O hole
Weight	: 2.4kg (gross)
Compliance	: SS 563 : Part 1 & 2, SS IEC 60598-2-22
Warranty	: 1 year

KEY FEATURES

- > Using Surface Mount Technology LED
- > High Durability & Reliability
- > Low Heat
- > Low Maintenance
- > Low Power Consumption
- > No "Black Ends"



Type and batch tested with
PSB PLS-LISTED LABEL



355 x 190mm

Fully-recessed
Low Level Exit Sign



IP30
CLASS I

ORDERING GUIDE (Please check with Sales Dept if customisation is required)

Single Sided	Legend
BLR/M/W5100	
BLR/M/W5100 (R)	
BLR/M/W5100 (L)	
BLR/M/W510RM	
BLR/M/W510RM (E)	
BLR/M/W510RM (W)	

EMERGENCY POWER PACKS CONVERSION KIT

Emergency kit for fluorescent lamp fitting



● MEM/M/128E MINI

● 4.8V 2.5AH
(Cane)

or

● 4.8V 2.5AH
(Side)

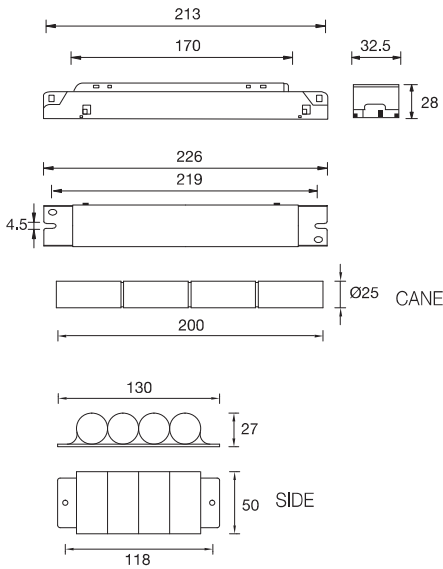

TECHNICAL DATA

Mode of Operation	: Maintained*
Lamp	: 4-pin fluorescent, PL/PLC and 2D lamps
Rated Duration	: 2 hrs and others
Mains Supply	: 230 Volts, 50/60Hz
Power Consumption	: < 3.9W
Battery	: High temp Nickel Cadmium
Charge Monitor	: Green LED Ø5mm
Test Facility	: Push button switch
Safety Feature	: Low volt cut-off preventing battery overdischarge
Fitting Construction	: Electro galvanised steel with epoxy powder coating
Weight (Module only)	: 0.20kg (gross)
Compliance	: IEC 61347-2-7
Warranty	: 1 year

Dimension: mm NTS

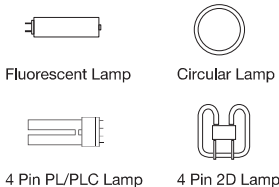

Type and batch tested with
PSB PLS-LISTED LABEL



ORDERING GUIDE

(Please check with Sales Dept if customisation is required)

Model	Lamp	For use with	Battery
MEM/M/114E MINI	T5 14W	Conventional and Electronic ballast	3.6V 1.8 AH
MEM/M/114E MINI	PLC10-26W 4-pin, T8 18W		3.6V 2.5 AH
MEM/M/114E MINI (Dimension:190x31x23mm)	T5 14W (MAINLY FOR 2FT BARE BTN)		3.6V 1.8 AH C3C3 (Dimension:150x30x15mm)
MEM/M/128E MINI	T5 28W, T8 36W		4.8V 2.5 AH
MEM/M/154E MINI	T5 35W, T5 49W, T5 54W, T8 58W		6.0V 2.5 AH
MEM/M/154E MINI	T5 35W, T5 49W, T5 54W, T8 58W		6.0V 4.5 AH

*Note:

Can be incorporated into combined maintained, combined non-maintained and non-maintained mode of operation.



Specifications subject to changes without prior notice.



Emergency kit for LED lamp fitting

EMERGENCY POWER PACKS CONVERSION KIT



• MEM/M/LED MINI

• 6.0V 1.8AH
(Cane)

or

• 6.0V 1.8AH
(Side)

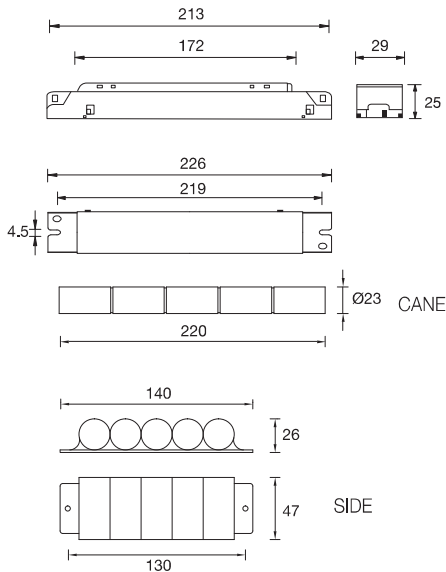

Dimension: mm NTS



 Type and batch tested with
PSB PLUS-LISTED LABEL



TECHNICAL DATA

Mode of Operation	: Maintained*
Lamp	: LED Lamp
Rated Duration	: 2hrs and others
Mains Supply	: 230 Volts, 50/60Hz
Power Consumption	: < 2.9W
Battery	: High temp Nickel Cadmium
Charge Monitor	: Green LED Ø5mm
Test Facility	: Push button switch
Safety Feature	: Low volt cut-off preventing battery overdischarge
Fitting Construction	: Electro galvanised steel with epoxy powder coating
Weight (Module only)	: 0.20kg (gross)
Compliance	: IEC 61347-2-7, IEC 61347-2-13, IEC 62384
Warranty	: 1 year

ORDERING GUIDE (Please check with Sales Dept if customisation is required)

Model	Lamp
MEM/M/LED MINI	2ft to 5ft T5/T8 LED Lamp

*Note:

Can be incorporated into combined maintained, combined non-maintained and non-maintained mode of operation.

** Please ensure that your LED Lamp & Driver are suitable for Emergency installation.

EMERGENCY POWER PACKS POWER PACK

Emergency power pack for 4-pin PL/PLC and 2D lamp fitting



● MPP/M/PLC13-18E NC

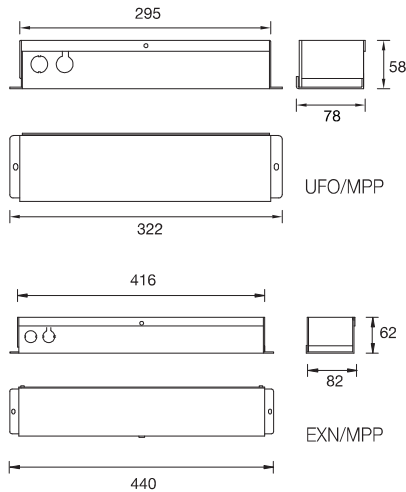

TECHNICAL DATA

Mode of Operation	: Maintained*
Lamp	: 4-pin PL/PLC and 2D lamps
Rated Duration	: 2 hrs and others
Mains Supply	: 230 Volts, 50/60Hz
Power Consumption	: < 3.5W
Battery	: High temp Nickel Cadmium
Charge Monitor	: Green LED Ø5mm
Test Facility	: Push button switch
Safety Feature	: Low volt cut-off preventing battery overdischarge
Fitting Construction	: Electro galvanised steel with epoxy powder coating
Cable Entry	: Ø20mm K/O hole
Weight	: 1.9kg (gross)
Compliance	: IEC 61347-2-7
Warranty	: 1 year

Dimension: mm NTS



4 Pin PL/PLC Lamp



4 Pin 2D Lamp

ORDERING GUIDE (Please check with Sales Dept if customisation is required)

Model	Lamp	For use with	Remote box size
MPP/M/PLC13-18E NC	PLC10- 26W 4-pin	Conventional and Electronic ballast	UFO/MPP
MPP/M/PLC58E NC	PLT32W-42W 4-pin		EXN/MPP

*Note:

Can be incorporated into combined maintained, combined non-maintained and non-maintained mode of operation.



Type and batch tested with
PSB PLS-LISTED LABEL



IP20
CLASS I



Specifications subject to changes without prior notice.



Emergency power pack for LED downlight

EMERGENCY POWER PACKS POWER PACK



● MPP/M/LED

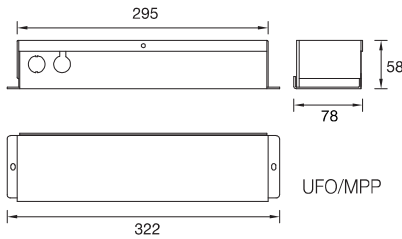

Dimension: mm NTS

TECHNICAL DATA

- Mode of Operation : Maintained*
- Lamp : LED Lamp
- Rated Duration : 2 hrs and others
- Mains Supply : 230 Volts, 50/60Hz
- Power Consumption : < 2.9W
- Battery : High temp Nickel Cadmium
- Charge Monitor : Green LED Ø5mm
- Test Facility : Push button switch
- Safety Feature : Low volt cut-off preventing battery overdischarge
- Fitting Construction : Electro galvanised steel with epoxy powder coating
- Cable Entry : Ø20mm K/O hole
- Weight : 1.3kg (gross)
- Compliance : IEC 61347-2-7, IEC 61347-2-13, IEC 62384
- Warranty : 1 year

ORDERING GUIDE (Please check with Sales Dept if customisation is required)

Model	Lamp
MPP/M/LED	LED Downlight

*Note:

Can be incorporated into combined maintained, combined non-maintained and non-maintained mode of operation.

** Please ensure that your LED Lamp & Driver are suitable for Emergency installation.

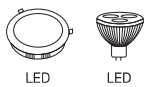

 Type and batch tested with
PSB PLS-LISTED LABEL

 F
IP20
CLASS I

S I N C E 1 9 7 8

Specifications subject to changes without prior notice.



EMERGENCY POWER PACKS BRITELITE

Emergency power pack for 12 volt lamp fitting



● EXN/M/150

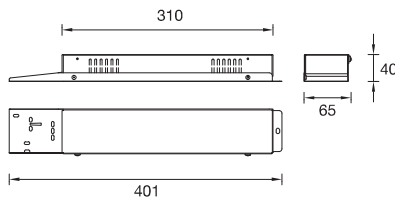

Dimension: mm NTS

TECHNICAL DATA

Mode of Operation	: Non-maintained*
Lamp	: 12V LED lamp / 12V 50W halogen lamp (max)
Rated Duration	: Refer to Ordering Guide
Mains Supply	: 230 Volts, 50/60Hz
Power Consumption	: < 3.5W
Battery	: High temp Nickel Cadmium
Charge Monitor	: Green LED Ø5mm
Test Facility	: Push button switch
Safety Feature	: Low volt cut-off preventing battery overdischarge
Fitting Construction	: Electro galvanised steel with epoxy powder coating
Cable Entry	: Ø20mm K/O hole
Weight	: 1.6kg (gross)
Compliance	: IEC 61347-2-7
Warranty	: 1 year

ORDERING GUIDE (Please check with Sales Dept if customisation is required)

Model	Lamp	Duration (hr)
EXN/M/150	12V LED Lamp	2
	12V 50W Halogen	> 1
	12V 20W Halogen	2

*Note:
For maintained mode, lamp, lamp fixture and 230V/12V main step-down transformer are not included.
Step-down transformer can be installed into remote box or onto the lamp fixture at site.

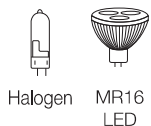

Halogen MR16 LED

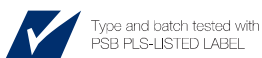

EMERGENCY POWER PACKS STARLITE

LED Auxiliary emergency power pack
(For Incorporate into light fitting or remote for downlight)



• UFO/NM/L101 NC (Auxiliary)

• Rectangle or • Square or • Round

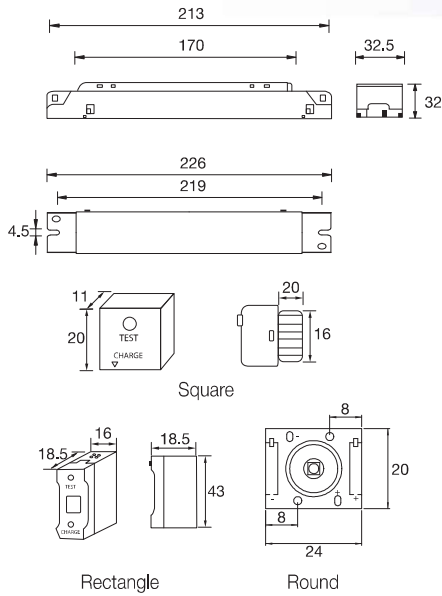

TECHNICAL DATA

- Mode of Operation : Non-maintained
- Lamp : 1W High Power LED
- Rated Duration : 2 hrs and others
- Mains Supply : 230 Volts, 50/60Hz
- Power Consumption : < 0.9W
- Battery : High temp Nickel Cadmium
- Charge Monitor : Green LED
- Test Facility : Tactile switch
- Safety Feature : Low volt cut-off preventing battery overdischarge
- Fitting Construction : Electro galvanised steel with epoxy powder coating
- Weight (Module only) : 0.25kg (gross)
- Compliance : SS563 : Part 1 & 2, SS IEC 60598-2-22
- Warranty : 1 year

ORDERING GUIDE (Please check with Sales Dept if customisation is required)

Model	Lamp	Battery type
UFO/NM/L101 NC (Auxiliary)	1W LED	Nickel Cadmium

Dimension: mm NTS
High Power L.E.D

KEY FEATURES

- > High Brightness Output
- > High Lumen/watt Efficiency
- > Low Power Consumption
- > Low Maintenance
- > Long Lifespan



Specifications subject to changes without prior notice.



EMERGENCY POWER PACKS STARLITE

LED Auxiliary emergency power pack
(For Incorporate into light fitting or remote for downlight)



• UFO/NM/L103 (AUXILIARY)

• Rectangle or • Round

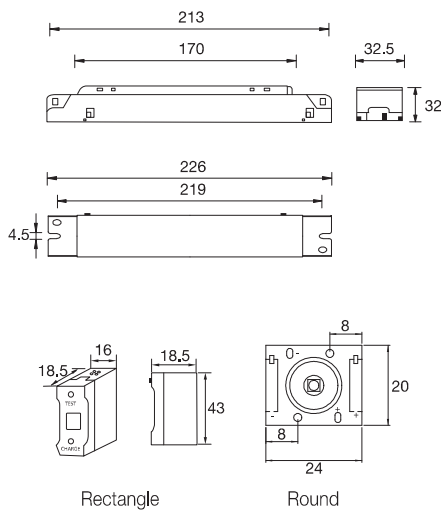

Rectangle

Round

Dimension: mm NTS
High Power L.E.D

KEY FEATURES

- > High Brightness Output
- > High Lumen/watt Efficiency
- > Low Power Consumption
- > Low Maintenance
- > Long Lifespan



Type and batch tested with
PSB PLS-LISTED LABEL



TECHNICAL DATA

Mode of Operation	: Non-maintained
Lamp	: 3W High Power LED
Rated Duration	: 2 hrs and others
Mains Supply	: 230 Volts, 50/60Hz
Power Consumption	: < 1.1W
Battery	: High temp Nickel Cadmium
Charge Monitor	: Green LED
Test Facility	: Tactile switch
Safety Feature	: Low volt cut-off preventing battery overdischarge
Fitting Construction	: Electro galvanised steel with epoxy powder coating
Weight (Module only)	: 0.25kg (gross)
Compliance	: SS563 : Part 1 & 2, SS IEC 60598-2-22
Warranty	: 1 year

ORDERING GUIDE (Please check with Sales Dept if customisation is required)

Model	Lamp	Battery type
UFO/NM/L103 (AUXILIARY)	3W LED	Nickel Cadmium



Specifications subject to changes without prior notice.



• UFR.3.NC180.NM

• UFDR.3.NC180.NM

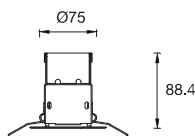
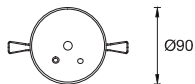

UFR.3.NC180.NM

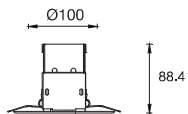
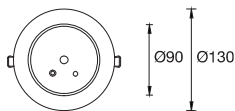

UFDR.3.NC180.NM

Dimension: mm NTS

High Power L.E.D

KEY FEATURES

- > High Brightness Output
- > High Lumen/watt Efficiency
- > Low Power Consumption
- > Low Maintenance
- > Long Lifespan



TECHNICAL DATA

- Mode of Operation : Non-Maintained
- Lamp : 3W High Power LED
- Rated Duration : 3 hrs and others
- Mains Supply : 230 Volts, 50/60Hz
- Power Consumption : < 1.4W
- Battery : High temp Nickel Cadmium
- Charge Monitor : Green LED
- Test Facility : Tactile switch
- Safety Feature : Low volt cut-off preventing battery overdischarge
- Fitting Construction : Electro galvanised steel with epoxy powder coating
- Mounting : Recess
- Weight : 0.8kg (gross)
- Compliance : SS 563 : Part 1 & 2, SS IEC 60598-2-22
- Warranty : 1 year

ORDERING GUIDE *(Please check with Sales Dept if customisation is required)*

Model	Lamp	Battery type
UFR.3.NC180.NM	3W LED	Nickel Cadmium
UFDR.3.NC180.NM	3W LED	Nickel Cadmium

EMERGENCY LIGHTS UFO

LED Non-maintained recess mount high lumen output emergency light



● UBDR.10.NC120.NM

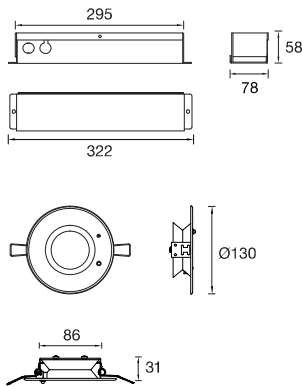

Dimension: mm NTS
High Power L.E.D

TECHNICAL DATA

Mode of Operation	: Non-Maintained
Lamp	: 10W High Power LED Module
Rated Duration	: 2hrs and others
Mains Supply	: 230 Volts, 50/60Hz
Power Consumption	: < 2.2W
Battery	: High temp Nickel Cadmium
Charge Monitor	: Green LED Ø5mm
Test Facility	: Micro Switch
Safety Feature	: Low volt cut-off preventing battery overdischarge
Fitting Construction	: Electro galvanised steel with epoxy powder coating
Mounting	: Recess
Cable Entry	: Ø20mm K/O hole
Weight	: 1.6kg (gross)
Compliance	: SS 563 : Part 1 & 2, SS IEC 60598-2-22
Warranty	: 1 year

KEY FEATURES

- > High Brightness Output
- > High Lumen/watt Efficiency
- > Standard Size Application for Both Accessible and Inaccessible Ceiling
- > Low Power Consumption
- > Low Maintenance
- > Long Lifespan
- > Mainly Use for High Ceiling (> 8 metre)

ORDERING GUIDE (Please check with Sales Dept if customisation is required)

Model	Lamp	Battery type
UBDR.10.NC120.NM	10W LED Module	Nickel Cadmium



Type and batch tested with
PSB PLS-LISTED LABEL



Ø110mm

Recess Mount
Emergency Luminaire



IP20
CLASS I



Specifications subject to changes without prior notice.



● UF.3.NC180.NM

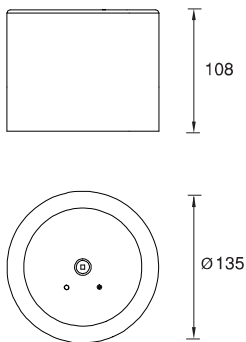

Dimension: mm NTS
High Power L.E.D

TECHNICAL DATA

- Mode of Operation : Non-Maintained
- Lamp : 3W High Power LED
- Rated Duration : 3 hrs and others
- Mains Supply : 230 Volts, 50/60Hz
- Power Consumption : < 1.4W
- Battery : High temp Nickel Cadmium
- Charge Monitor : Green LED
- Test Facility : Tactile switch
- Safety Feature : Low volt cut-off preventing battery overdischarge
- Fitting Construction : Electro galvanised steel with epoxy powder coating
- Mounting : Ceiling
- Cable Entry : Ø20mm K/O hole
- Weight : 0.74 kg (gross)
- Compliance : SS 563 : Part 1 & 2, SS IEC 60598-2-22
- Warranty : 1 year

KEY FEATURES

- > High Brightness Output
- > High Lumen/watt Efficiency
- > Low Power Consumption
- > Low Maintenance
- > Long Lifespan

ORDERING GUIDE *(Please check with Sales Dept if customisation is required)*

Model	Lamp	Battery type
UF.3.NC180.NM	3W LED	Nickel Cadmium



Surface Mount
Emergency Luminaire



EMERGENCY LIGHTS UFO

LED Non-maintained surface mount high lumen output emergency light



• UF.10.NC120.NM

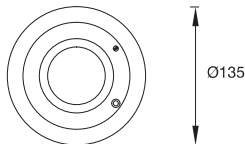

Dimension: mm NTS
High Power L.E.D

TECHNICAL DATA

Mode of Operation	: Non-Maintained
Lamp	: 10W High Power LED Module
Rated Duration	: 2hrs and others
Mains Supply	: 230 Volts, 50/60Hz
Power Consumption	: < 2.2W
Battery	: High temp Nickel Cadmium
Charge Monitor	: Green LED Ø5mm
Test Facility	: Micro switch
Safety Feature	: Low volt cut-off preventing battery overdischarge
Fitting Construction	: Electro galvanised steel with epoxy powder coating
Mounting	: Ceiling
Cable Entry	: Ø20mm K/O hole
Weight	: 1.5kg (gross)
Compliance	: SS 563 : Part 1 & 2, SS IEC 60598-2-22
Warranty	: 1 year

KEY FEATURES

- > High Brightness Output
- > High Lumen/watt Efficiency
- > Low Power Consumption
- > Low Maintenance
- > Long Lifespan
- > Mainly use for high ceiling (> 8 meters)

ORDERING GUIDE (Please check with Sales Dept if customisation is required)

Model	Lamp	Battery type
UF.10.NC120.NM	10W LED Module	Nickel Cadmium



Surface Mount
Emergency Luminaire



Specifications subject to changes without prior notice.



LED Economical non-maintained emergency twin light

EMERGENCY LIGHTS MINNIE



● MR203L NC



● MR203L NC WP
(Weatherproof)

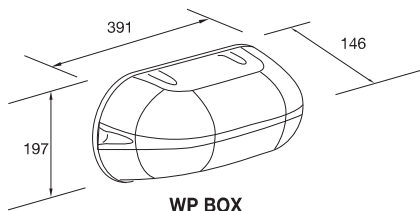
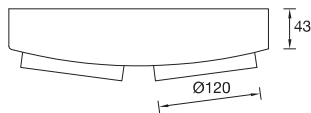
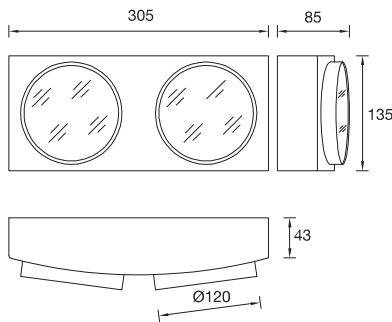

WP BOX

Dimension: mm NTS

High Power L.E.D

KEY FEATURES

- > High Brightness Output
- > High Lumen/watt Efficiency
- > Low Power Consumption
- > Low Maintenance
- > Long Lifespan



Surface Mount
Energy Efficient
Emergency Luminaire



IP30 / IP54



TECHNICAL DATA

- Mode of Operation : Non-Maintained
- Lamp : 2 x 3W High Power LED
- Rated Duration : 2hrs and others
- Mains Supply : 230 Volts, 50/60Hz
- Power Consumption : < 1.1W
- Battery : High temp Nickel Cadmium
- Charge Monitor : Green LED Ø5mm
- Test Facility : Micro switch
- Safety Feature : Low volt cut-off preventing battery overdischarge
- Fitting Construction : Injection moulded thermoplastic ABS;
UL 94V-0 flame rating, two fully adjustable glare-free round shaped heads
- Mounting : Wall or ceiling. The snap-fit design will facilitate easy installations. Easily removable mounting and knockout holes are provided
- Cable Entry : Ø20mm K/O hole
- Weight : 1.2kg (gross)
- Compliance : SS 563 : Part 1 & 2, SS IEC 60598-2-22
- Warranty : 1 year

ORDERING GUIDE (Please check with Sales Dept if customisation is required)

Model	Lamp	Battery type
MR203L NC	2 x 3W LED	Nickel Cadmium
MR203L NC WP	2 x 3W LED	Nickel Cadmium

EMERGENCY LIGHTS PROVIDER

LED Aesthetical non-maintained emergency twin light



● PP203L NC

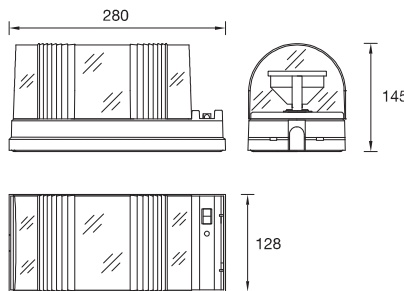

Dimension: mm NTS
High Power L.E.D

TECHNICAL DATA

Mode of Operation	: Non-Maintained
Lamp	: 2 x 3W High Power LED
Rated Duration	: 2 hrs and others
Mains Supply	: 230 Volts, 50/60Hz
Power Consumption	: < 2W
Battery	: High temp Nickel Cadmium
Charge Monitor	: Green LED Ø5mm
Test Facility	: Rocker switch
Safety Feature	: Low volt cut-off preventing battery overdischarge
Housing	: High impact thermoplastic enclosure in a matt white finish. Transparent half cylinder Polycarbonate lamp shield with fresnel pattern and fully adjustable self-locking lamp heads
Mounting	: Wall or ceiling. The snap-fit design will facilitate easy installations. Easily removable mounting and knockout holes are provided (fitting can be positioned vertically or horizontally)
Cable Entry	: Ø20mm K/O hole
Weight	: 1.2kg (gross)
Compliance	: SS 563 : Part 1 & 2, SS IEC 60598-2-22
Warranty	: 1 year

KEY FEATURES

- > High Brightness Output
- > High Lumen/watt Efficiency
- > Low Power Consumption
- > Low Maintenance
- > Long Lifespan

ORDERING GUIDE (Please check with Sales Dept if customisation is required)

Model	Lamp	Battery type
PP203L NC	2 x 3W LED	Nickel Cadmium



Type and batch tested with
PSB PLS-LISTED LABEL

Surface Mount
Flexible Application
Emergency Luminaire



IP30



Specifications subject to changes without prior notice.



SMT LED Non-maintained emergency light
Indoor, outdoor, corrosion resistant weatherproof emergency light

EMERGENCY LIGHTS CLASSIC



● JW/NM/W5100

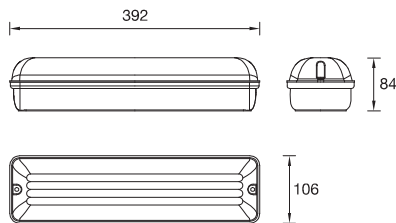

Dimension: mm NTS

TECHNICAL DATA

Mode of Operation	: Non-Maintained
Lamp	: Maxspid 1W SMT LED Lamp
Rated Duration	: 3 hrs and others
Mains Supply	: 230 Volts, 50/60Hz
Power Consumption	: < 1.6W
Battery	: High temp Nickel Cadmium
Charge Monitor	: Green LED Ø5mm
Test Facility	: Push button switch
Safety Feature	: Low volt cut-off preventing battery overdischarge
Housing	: Injection moulded fire retardant high impact polycarbonate diffuser and base. Clear reeded diffuser is designed for non-glare and greater light distribution
Mounting	: Wall or ceiling
Cable Entry	: Ø20mm K/O hole
Weight	: 1.0kg (gross)
Compliance	: SS 563 : Part 1 & 2, SS IEC 60598-2-22
Warranty	: 1 year

KEY FEATURES

- > Using Surface Mount Technology LED
- > High Durability & Reliability
- > Low Heat
- > Low Maintenance
- > Low Power Consumption
- > No "Black Ends"

ORDERING GUIDE (Please check with Sales Dept if customisation is required)

Model	Lamp	Battery type
JW/NM/W5100	1W SMT LED	Nickel Cadmium

Note:
Optional silkscreen printed legend on cover to convert into an emergency exit light.
*Heating strip applicable (for cold room used)



Surface Mount
Compact Emergency
Luminaire



Specifications subject to changes without prior notice.



EMERGENCY LIGHTS TWIN LAMP

LED Non-maintained emergency twin light



● MTL/NM/L203 NC

● MTL/NM/L203 NC WP
(Weatherproof)

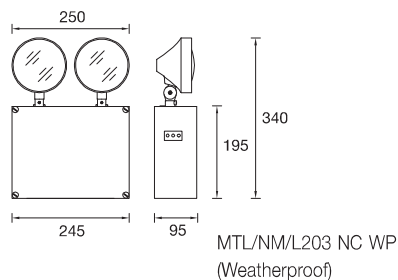
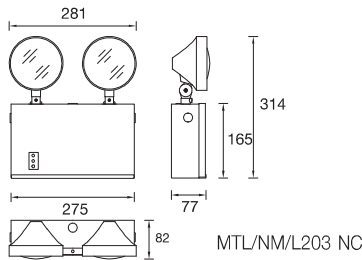

Dimension: mm NTS

High Power L.E.D

KEY FEATURES

- > High Brightness Output
- > High Lumen/watt Efficiency
- > Low Power Consumption
- > Low Maintenance
- > Long Lifespan



Type and batch tested with
PSB PLS-LISTED LABEL

Surface Mount
Wide Angle
Emergency Luminaire



IP30 / IP65

TECHNICAL DATA

Mode of Operation	: Non-Maintained
Lamp	: 2 x 3W High Power LED
Rated Duration	: 3 hrs and others
Mains Supply	: 230 Volts, 50/60Hz
Power Consumption	: < 2.2W
Battery	: High temp Nickel Cadmium
Charge Monitor	: Green LED Ø5mm
Test Facility	: Micro switch
Safety Feature	: Low volt cut-off preventing battery overdischarge
Fitting Construction	: Electro galvanised steel with epoxy powder coating The adjustable fire-retardant lamp-heads allow flexibility in angle of projection. Lamp heads comes with anti-glare lens
Mounting	: Wall
Cable Entry	: Ø20mm K/O hole
Weight	: 2.6kg (gross)
Compliance	: SS 563 : Part 1 & 2, SS IEC 60598-2-22
Warranty	: 1 year

ORDERING GUIDE (Please check with Sales Dept if customisation is required)

Model	Lamp	Battery type
MTL/NM/L203 NC	2 x 3W LED	Nickel Cadmium
MTL/NM/L203 NC WP	2 x 3W LED	Nickel Cadmium

*Heating strip applicable (for cold room used)



Specifications subject to changes without prior notice.



Surface mount single sided slave unit

CUSTOMIZED SIGNAGE LEDER



● ES/W5100

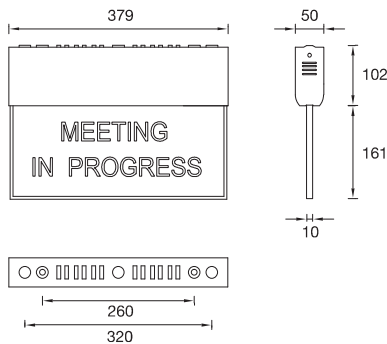

Dimension: mm NTS

TECHNICAL DATA

- Mode of Operation : Slave
- Lamp : Maxspid 1W SMT LED Lamp
- Mains Supply : 230 Volts, 50/60Hz
- Fitting Construction : Electro galvanised steel with epoxy powder coating
- Diffuser : Fire retardant moulded acrylic
- Legend : MEETING IN PROGRESS
(Engraving on letter border only)
other legend optional
- Mounting : Wall or ceiling
- Cable Entry : Ø20mm K/O hole
- Weight : 2.5kg (gross)

ORDERING GUIDE (Please check with Sales Dept if customisation is required)

Model	Lamp
ES/W5100	1W SMT LED

OTHER LEGENDS



Surface Mount
Slim Sign



CUSTOMIZED SIGNAGE BOXER

Box type single sided slave unit



• MLS/W5100

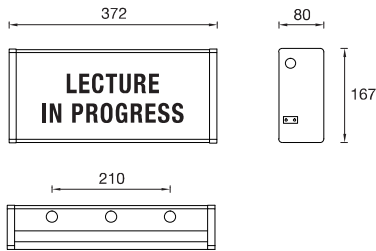

Dimension: mm NTS

TECHNICAL DATA

- Mode of Operation : Slave
- Lamp : Maxspid 1W SMT LED Lamp
- Mains Supply : 230 Volts, 50/60Hz
- Fitting Construction : Electro galvanised steel with epoxy powder coating
- Diffuser : Fire retardant moulded acrylic
- Legend : LECTURE IN PROGRESS
(Black legend and white background)
other legend optional
- Mounting : Wall or ceiling
- Cable Entry : Ø20mm K/O hole
- Weight : 2.0kg (gross)

ORDERING GUIDE (Please check with Sales Dept if customisation is required)

Model	Lamp	
MLS/W5100	1W SMT LED	** White legend or white background
MLS/W5100 (2x4.5W)	2x4.5W LED	** Red legend and black background

OTHER LEGENDS

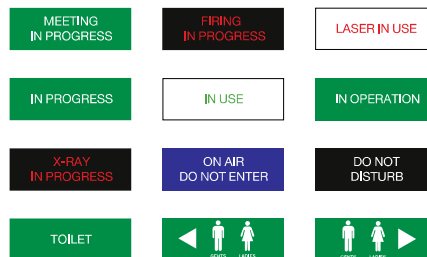

Surface Mount
Box Sign



Specifications subject to changes without prior notice.



Emergency kit for 2-pin PL/PLC and 2D lamp fitting

EMERGENCY POWER PACKS CONVERSION KIT

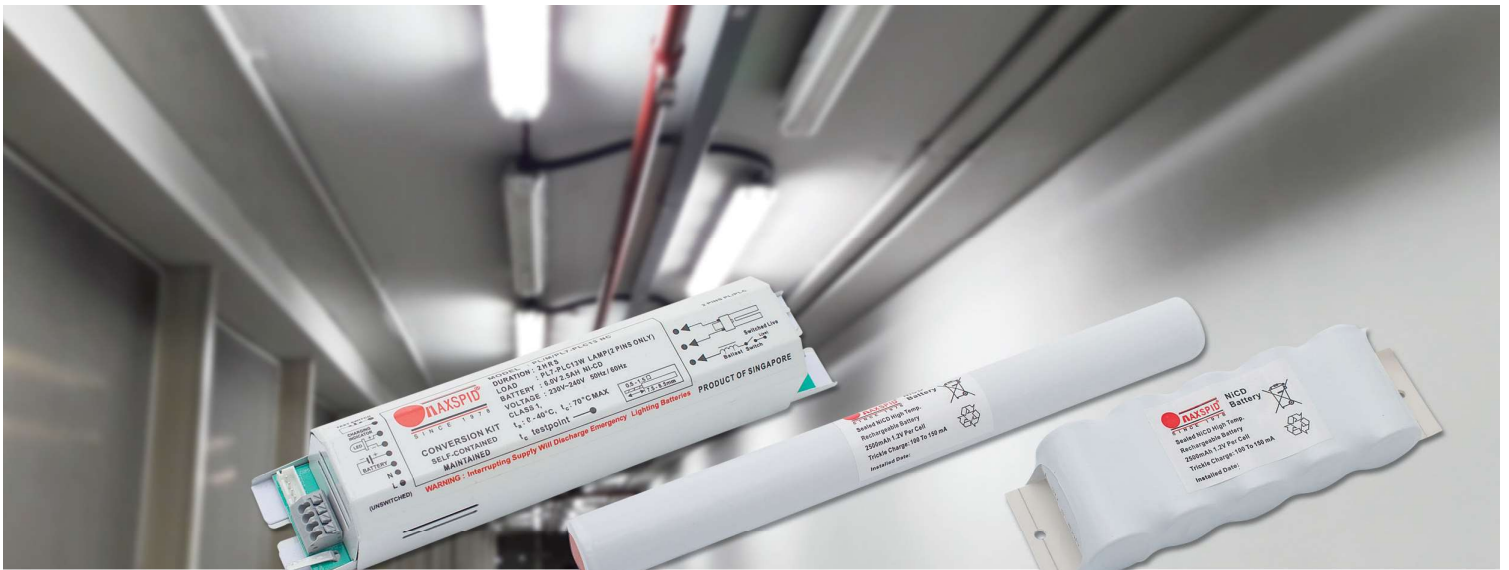

● PL/M/PL7-PLC13 NC

● 6.0V 2.5AH (Cane)

or

● 6.0V 2.5AH (Side)

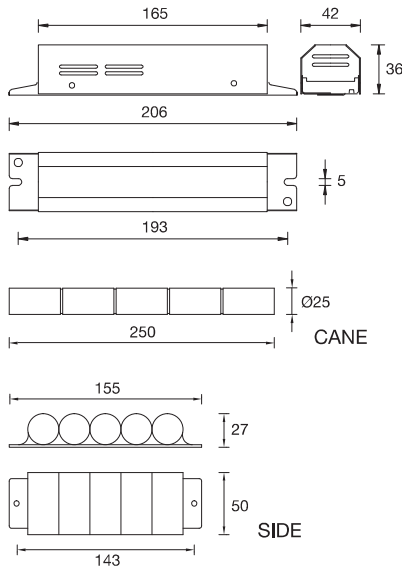

Dimension: mm NTS



TECHNICAL DATA

- Mode of Operation : Maintained*
- Lamp : 2-pin PL/PLC and 2D lamps
- Rated Duration : 2hrs and others
- Mains Supply : 230 Volts, 50/60Hz
- Power Consumption : < 6.5W
- Battery : High temp Nickel Cadmium
- Charge Monitor : Green LED Ø5mm
- Test Facility : Push button switch
- Safety Feature : Low volt cut-off preventing battery overdischarge
- Fitting Construction : Electro galvanised steel with epoxy powder coating
- Cable Entry : Ø20mm K/O hole
- Weight (module only) : 0.4kg (gross)
- Warranty : 1 year

ORDERING GUIDE (Please check with Sales Dept if customisation is required)

Model	Lamp
PL/M/PL7-PLC13 NC	PL7 - PLC13W
PL/M/PLC18-26 NC	PLC18 - 26W

*Note:

Can be incorporated into combined maintained, combined non-maintained and non-maintained mode of operation.



EMERGENCY POWER PACKS CONVERSION KIT

Emergency kit for AC LED Lamp



• MEM/M/LED-AC MINI

• 12.0V 4.5AH (C5C5)

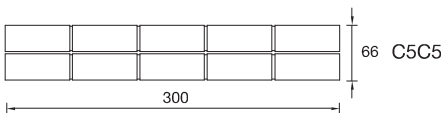
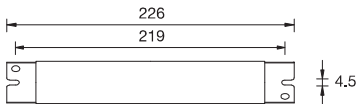
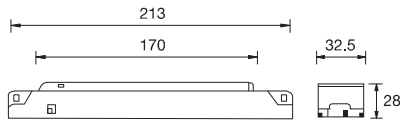

or

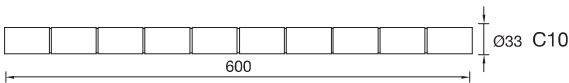

TECHNICAL DATA

Mode of Operation	: Maintained
Lamp	: AC LED Lamp
Rated Duration	: 2 hrs and others
Charging Time	: Min. 48 hrs
Mains Supply	: 230 Volts, 50/60Hz
Power Consumption	: < 4.7 W
Battery	: High temp Nickel Cadmium
Charge Monitor	: Green LED Ø5mm
Test Facility	: Push button switch
Safety Feature	: Low volt cut-off preventing battery overdischarge
Fitting Construction	: Electro galvanised steel with epoxy powder coating
Weight (module only)	: 0.4kg (gross)
Warranty	: 1 year

ORDERING GUIDE (Please check with Sales Dept if customisation is required)

Model	Lamp (For reference only)
MEM/M/LED-AC MINI	Osram 20W ST8 - HT4 - 170 - 865 AC LED Lamp
	Philips Master T8 19W AC LED Lamp

**Please ensure that your LED Lamp & Driver are suitable for Emergency installation.

Dimension: mm NTS



Emergency power pack for 2-pin PL/PLC
and 2D lamp fitting

EMERGENCY POWER PACKS POWER PACK



● MPP/M/PL7-PLC26

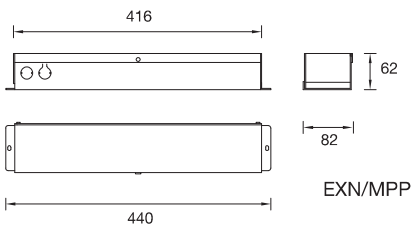
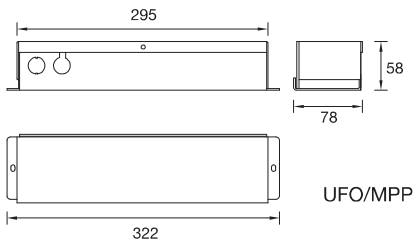

Dimension: mm NTS

TECHNICAL DATA

Mode of Operation	: Maintained
Lamp	: 2-pin PL/PLC and 2D lamps
Rated Duration	: 2 hrs and others
Mains Supply	: 230 Volts, 50/60Hz
Power Consumption	: < 7.2W
Battery	: Maintenance-free sealed Lead Calcium battery (High temp Nickel Cadmium available)
Charge Monitor	: Green LED Ø5mm
Test Facility	: Push button switch
Safety Feature	: Low volt cut-off preventing battery overdischarge
Fitting Construction	: Electro galvanised steel with epoxy powder coating
Cable Entry	: Ø20mm K/O hole
Weight	: 2.1kg (gross)
Warranty	: 1 year

ORDERING GUIDE (Please check with Sales Dept if customisation is required)

Model	Lamp	Remote box size	Battery Type
MPP/M/PL7-PLC26	PL7 - PLC26W	EXN/MPP	Sealed Lead Calcium
MPP/M/PL7-PLC13 NC	PL7 - PLC13W	UFO/MPP	Nickel Cadmium
MPP/M/PLC18-26 NC	PLC18 - 26W	EXN/MPP	Nickel Cadmium

*Note:

Can be incorporated into combined maintained, combined non-maintained and non-maintained mode of operation.



2 Pin PL/PLC Lamp



2 Pin 2D Lamp



IP20
CLASS I

TUNNEL EXIT LIGHTS TRILITE

Surface mount triangular slave unit



• TL/210RM

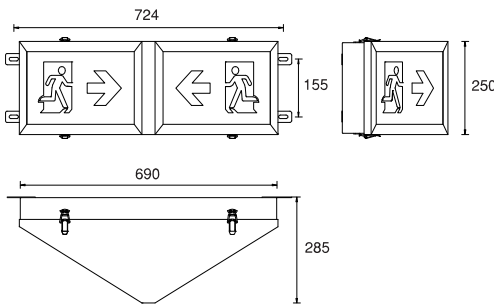

Dimension: mm NTS

TECHNICAL DATA

Mode of Operation	: Slave
Lamp	: 2 x 7W LED
Mains Supply	: 230 Volts, 50/60Hz
Fitting Construction	: 304 Stainless steel
Diffuser	: Tempered glass
Cable Entry	: Ø25mm hole
Mounting	: Wall
Weight	: 10kg (gross)
Compliance	: IEC 60598-1, IEC 62236-5, IEC 61000-4-11, CISPR 15

ORDERING GUIDE (Please check with Sales Dept if customisation is required)

Model	Legend
TL/210	EXIT EXIT
TL/210RM	EXIT EXIT

Surface Mount
Weatherproof
Tunnel Sign



TECHNICAL INFORMATION

STANDARD MODES OF OPERATION

NM Non-Maintained Mode

The lamp only operates in the event of a mains failure. An unswitched supply is essential. During the failure period the lamp runs from the battery. The battery is automatically recharged on the mains reconnection.

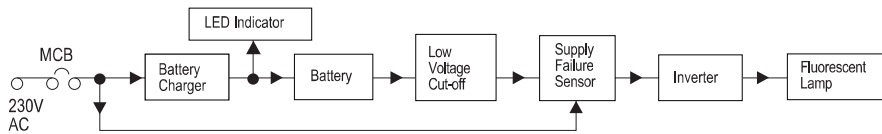

M Maintained Mode

The lamp operates at all times of occupation. A separate supply is required to drive the lamp when the main is healthy. This supply can be switched off to conserve lamp life during periods of no occupation. During failure the lamp runs from the battery.

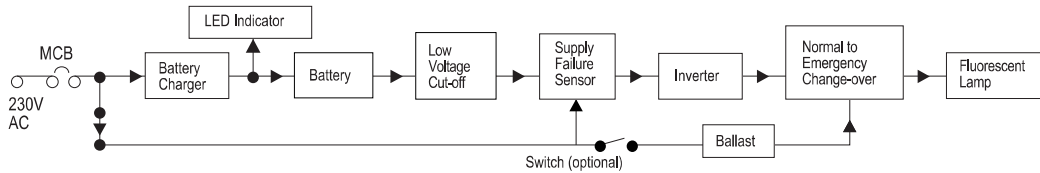

CNM Combined Non-Maintained Mode (formally called Sustained)

The luminaire has two or more lamps. One is energised from the emergency supply. The others are lit from the normal supply

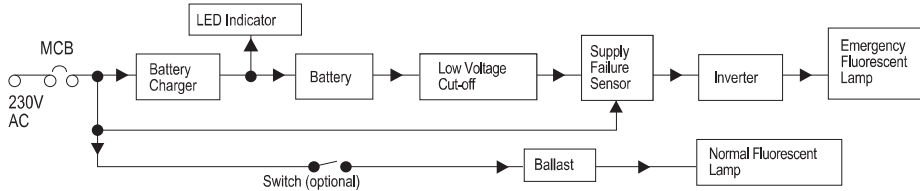





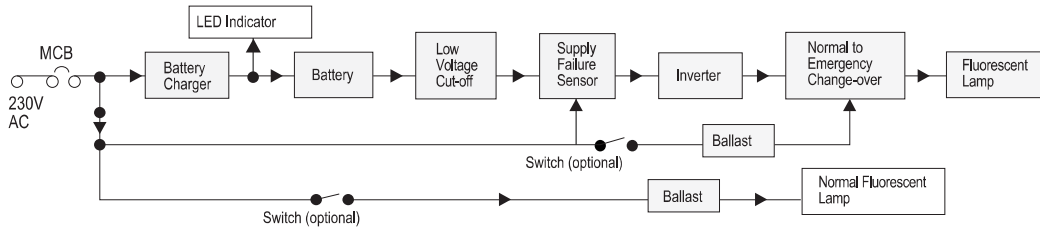

CM Combined Maintained Mode

The luminaire has two or more lamps. Both are energised from the normal supply but only one illuminates in the case of a mains failure.



Summary

Mode	 NM Non-Maintained	 M Maintained	 CNM Combined Non-Maintained	 CM Combined Maintained
Normal Supply	✗	✓	✗ ✓ ✓	✓ ✓ ✓
Power Failure	✓	✓	✓ ✗ ✗	✓ ✗ ✗
 Lamp illuminated		 Lamp not illuminated		 Normal Lamp on mains supply

OPERATION AND WIRING INFORMATION

>> **1. Typical wiring layout for non-maintained mode :**
 L (un-sw) (Unswitched Supply) and N as marked.

NM ●

1.01a) For 1x4-pin FL Lamp

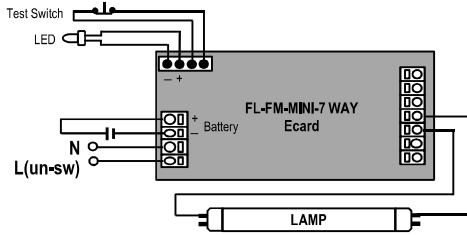

1.01b) For 1x4-pin FL Lamp

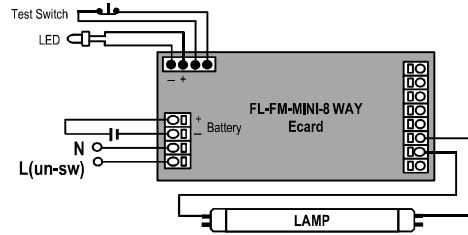

1.02) For SMT LED Lamp

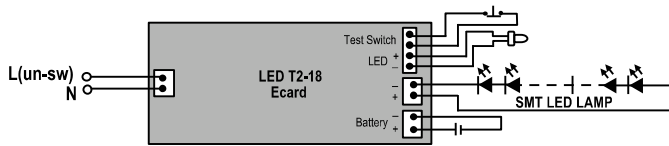

1.03a) For 1W or 3W LED Lamp

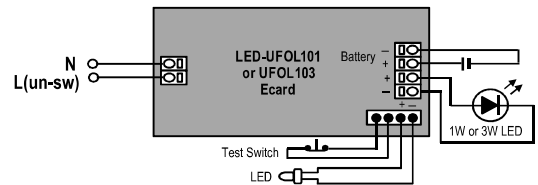

1.03b) For 1W LED Lamp

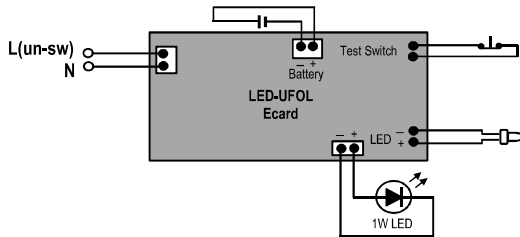

1.03c) For 1W LED Lamp

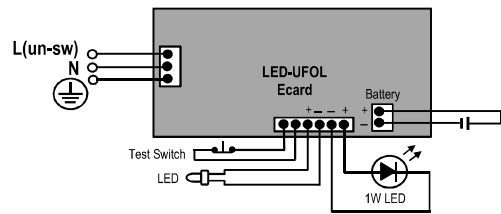

1.03d) For 1W or 3W LED Lamp

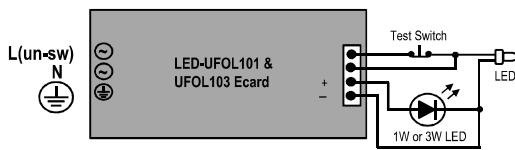

1.03e) For 3W LED Module

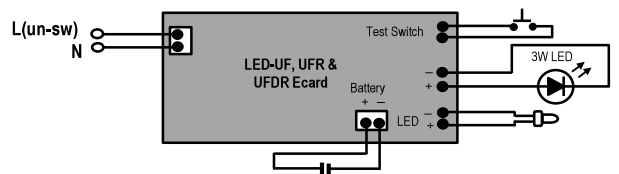

1.04) For 10W LED Module

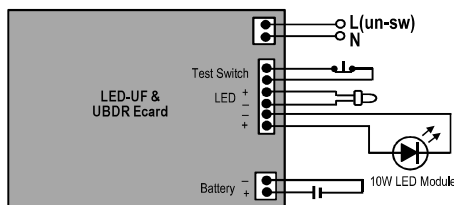

1.05) For 2x3W LED Lamp

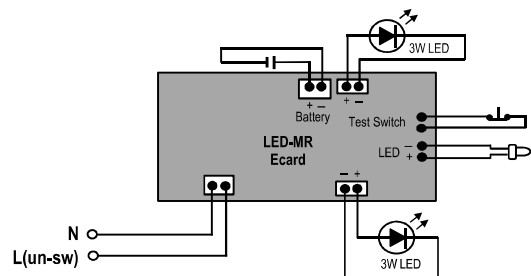

TECHNICAL INFORMATION

OPERATION AND WIRING INFORMATION

>> **1. Typical wiring layout for non-maintained mode :**
 L (un-sw) (Unswitched Supply) and N as marked.



1.06) For 2x3W LED Lamp

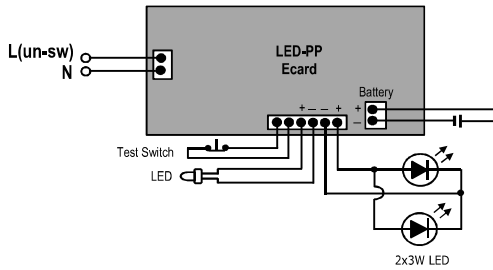

1.07) For 2x3W LED Lamp

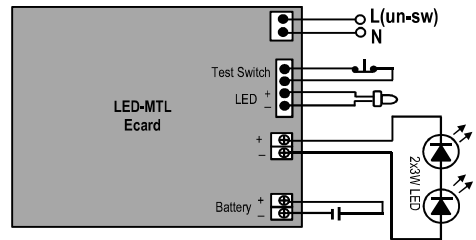

>> **2. Typical wiring layout for maintained mode with conventional ballast :**



L(sw) (Switched Supply), L(un-sw) (Unswitched Supply) and N as marked, not interchangeable and must be of the same phase as ELCB,

2.01) For 12V LED or 1x12V 20W to 50W (max) Halogen Lamp

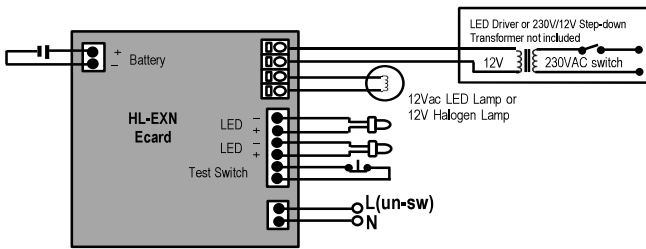

2.02) For 1x2-pin PL/PLC Lamp

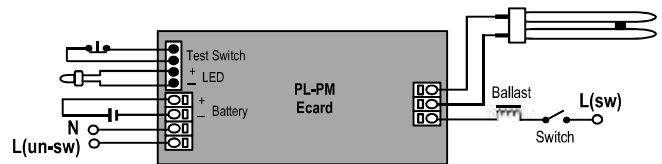

2.03a) For 1x4-pin FL Lamp

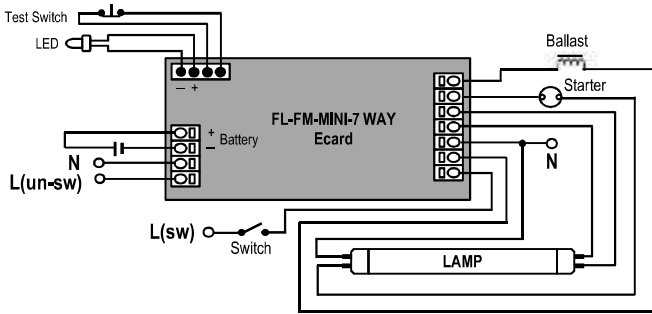

2.03b) For 1x4-pin PL/PLC Lamp

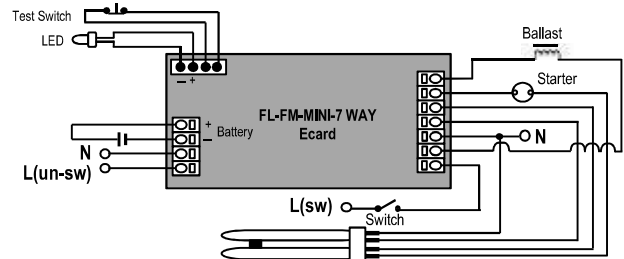

2.03c) For 1x4-pin FL Lamp

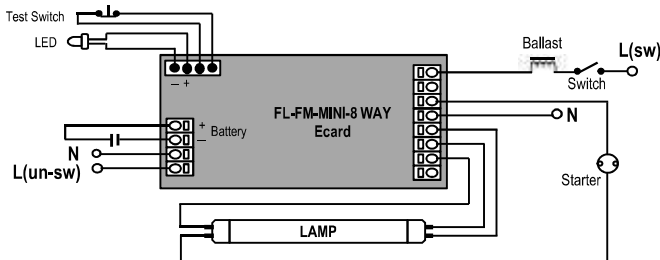

2.03d) For 1x4-pin PL/PLC Lamp

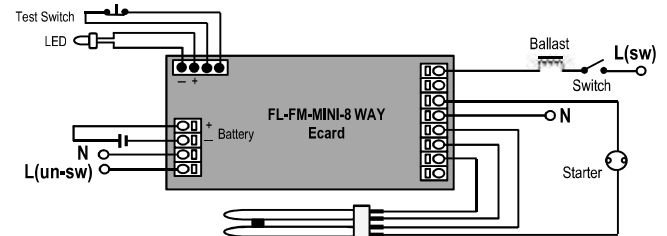

2.04a) For SMT LED Lamp

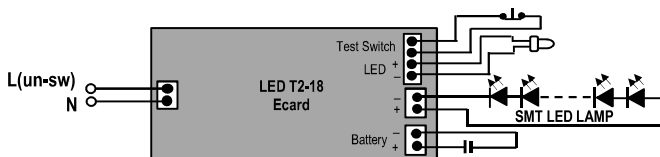

2.04b) For SMT LED Lamp

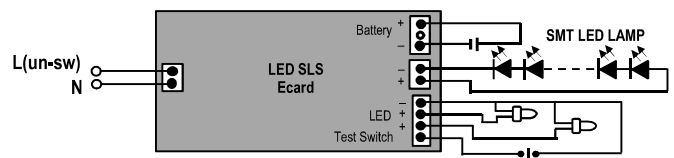

TECHNICAL INFORMATION

OPERATION AND WIRING INFORMATION

>> 3. Typical wiring layout for maintained mode with electronic ballast/driver: **M** 

L(sw) (Switched Supply), L(un-sw) (Unswitched Supply) and N as marked, not interchangeable and must be of the same phase as ELCB.

3.01) For 1x4-pin FL Lamp with electronic ballast

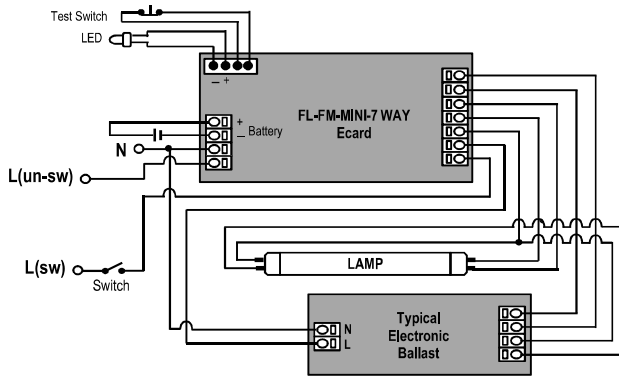

3.02) For 1x4-pin PL/PLC Lamp with electronic ballast

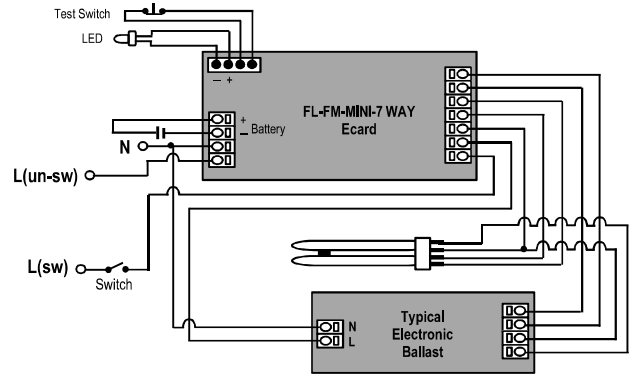

*Different wiring apply for different brand of electronic ballast

3.03) For 1x4-pin FL Lamp with electronic ballast

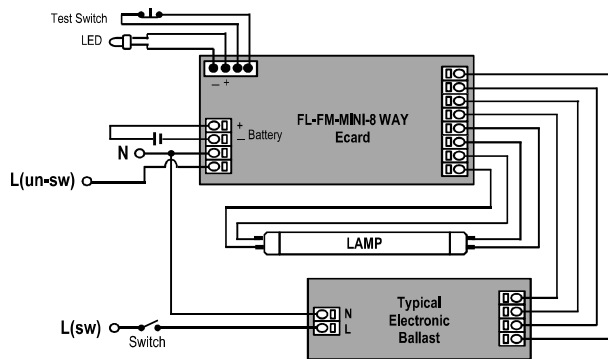

3.04) For 1x4-pin PL/PLC Lamp with electronic ballast

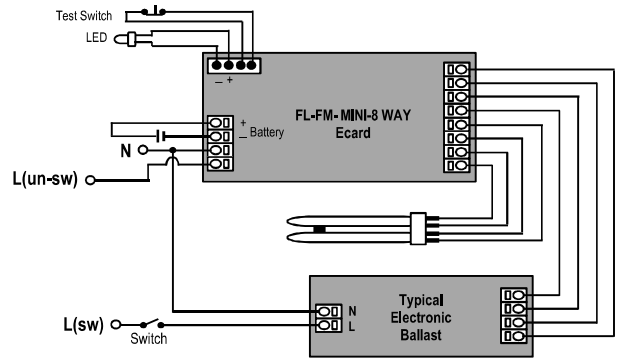

*Different wiring apply for different brand of electronic ballast

3.05) For T8 LED LAMP/LED Module

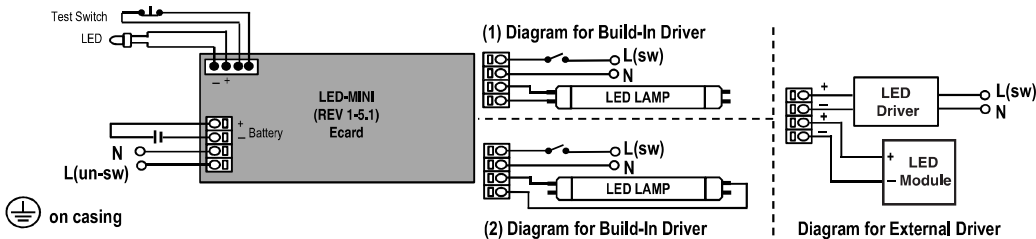

TECHNICAL INFORMATION

OPERATION AND WIRING INFORMATION

>> 3. Typical wiring layout for maintained mode with electronic ballast/driver: M ●

L(sw) (Switched Supply), L(un-sw) (Unswitched Supply) and N as marked, not interchangeable and must be of the same phase as ELCB.

3.06) For T8 LED LAMP/LED Module

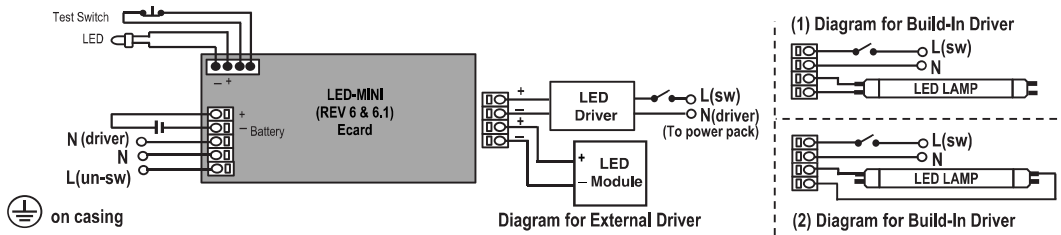

3.07) For AC LED LAMP

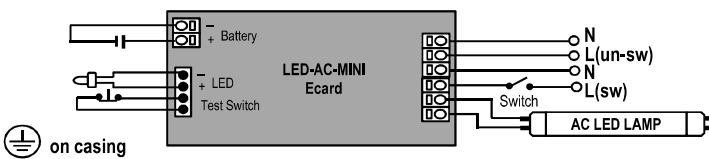

>> 4. Combined non-maintained mode: CNM ● ○ (formally known as sustained mode)

is obtained by combining one or more non-maintained mode lamp(s) with any number of normal lamp(s) in a luminaire.

>> 5. Typical wiring layout for combined maintained mode with conventional ballast: CM ● ○

L(sw) (Switched Supply), L(un-sw) (Unswitched Supply) and N as marked, not interchangeable and must be of the same phase as ELCB.

5.01) Combined Maintained for 2x4-pin FL Lamp in series

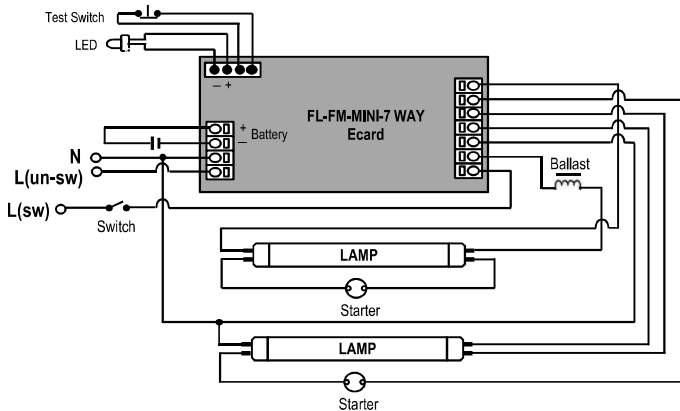

5.02) Combined Maintained for 2x4-pin FL Lamp in series

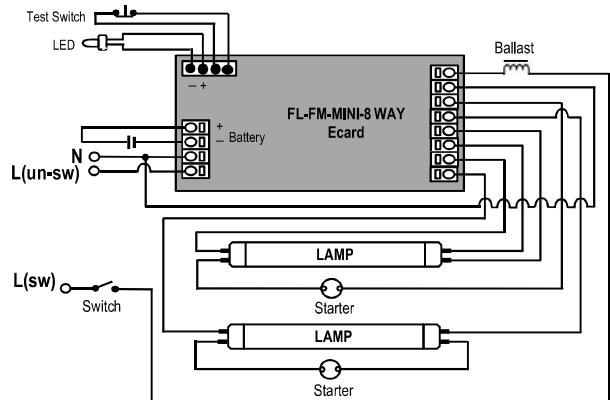

TECHNICAL INFORMATION

OPERATION AND WIRING INFORMATION

5.03) Combined Maintained for 2x2-pin PL7 to 9W Lamp in series

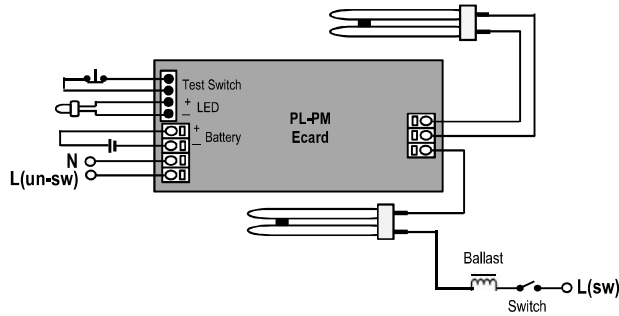

>> 6. Typical wiring layout for combined maintained mode with electronic ballast :



L(sw) (Switched Supply), L(un-sw) (Unswitched Supply) and N as marked, not interchangeable and must be of the same phase as ELCB.

6.01) For 2x4-pin FL Lamp with electronic ballast

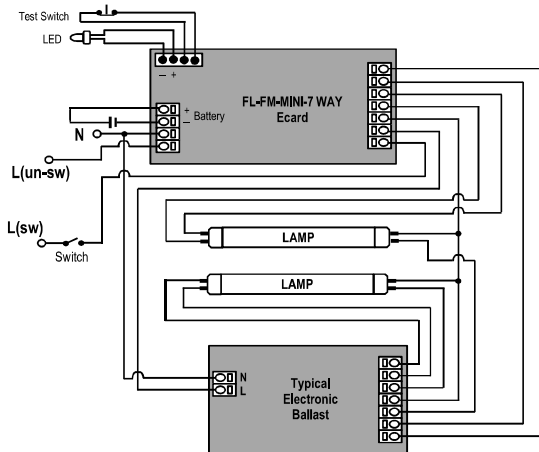

*Different wiring apply for different brand of electronic ballast

6.02) For 2x4-pin PL/PLC Lamp with electronic ballast

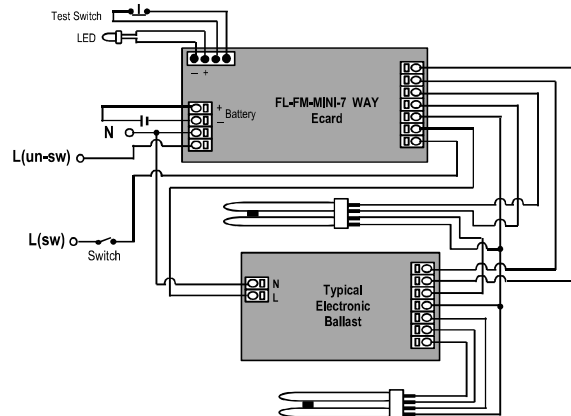

6.03) For 2x4-pin FL Lamp with electronic ballast

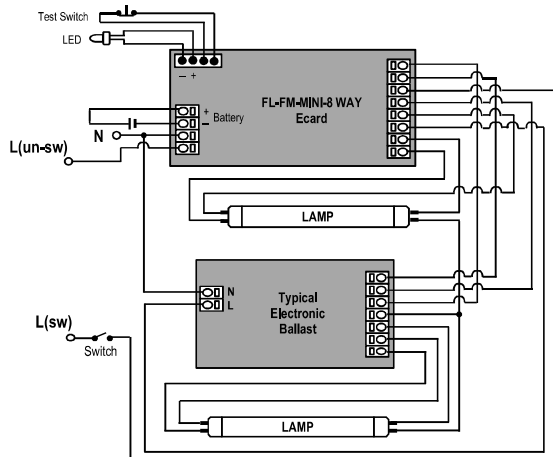

*Different wiring apply for different brand of electronic ballast

6.04) For 2x4-pin PL/PLC Lamp with electronic ballast

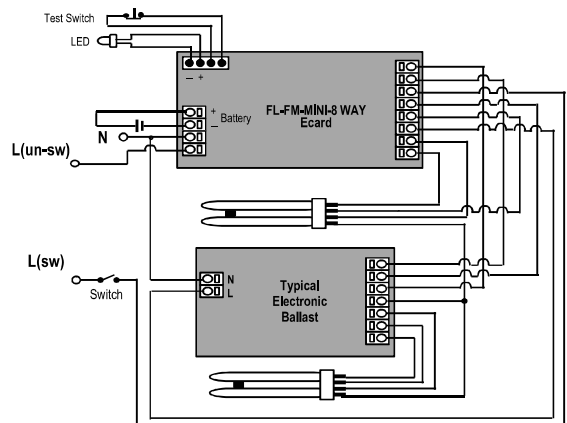

LIST OF SYMBOL/MARKING

SYMBOL AND MARKING INFORMATION

Symbol/Mark

Explanation



Luminaires suitable for direct mounting on normally flammable surfaces.



Class II luminaire:
Luminaire in which protection against electric shock does not rely on basic insulation only, but in which additional safety precautions such as double insulation or reinforced insulation are provided, there being no provision for protective earthing or reliance upon installation conditions.



Luminaire not suitable for covering with thermally insulated material.



Recommended hole size opened on mounting surface for installation of recessed luminaire.

CLASS I

Class I luminaire:
Luminaire in which protection against electric shock does not rely on basic insulation only, but which includes an additional safety precaution in such a way that means are provided for the connection of accessible conductive parts to the protective (earthing) conductor in the fixed wiring of the installation in such a way that accessible conductive parts cannot become live in the event of a failure of the basic insulation.

Ingress Protection Rating Table

- a) Protection of persons against contact with or approach to live parts and against contact with moving parts (other than smooth rotating shafts and the like) inside the enclosure and protection of the equipment against ingress of solid foreign bodies.

First characteristic numeral	Degree of protection	
	Short description	Brief details of objects which will be "excluded" from the enclosure.
2	Protected against solid objects greater than 12 mm	Fingers or similar objects not exceeding 80mm in length. Solid objects exceeding 12mm in diameter.
3	Protection against solid objects greater than 2,5mm	Tools, wires, etc., of diameter or thickness greater than 2,5mm. Solid objects exceeding 2,5mm in diameter.
5	Dust-protected	Ingress of dust is not totally prevented but dust does not enter in sufficient quantity to interfere with satisfactory operation of the equipment.
6	Dust-tight	No ingress of dust.

- b) Protection of the equipment inside the enclosure against harmful ingress of water.

Second characteristic numeral	Degree of protection	
	Short description	Details of the type of protection provided by the enclosure.
0	Non-protected	No special protection.
4	Protected against splashing water	Water splashed against the enclosure from any direction shall have no harmful effect.
5	Protected against water jets	Water projected by a nozzle against the enclosure from any direction shall have no harmful effect.

美德企业私人有限公司
MAXSPID ENTERPRISE PTE LTD
19 Kaki Bukit Place Singapore 416197



TEL +65 6748 1838 FAX +65 6749 1838
EMAIL mepl@maxspid.com.sg

www.maxspid.com
Edition 2019

